

AM/FM STEREO RECEIVER

SX-650

SERVICE MANUAL



 PIONEER®

MODEL SX-650 COMES IN FOUR VERSIONS DISTINGUISHED AS FOLLOWS:

Type	Voltage	Remarks
KC KU	120V 120V	CSA (Canada) approved. UL (U.S.A.) approved.
HG	220V and 240V (Switchable)	SEMKO (Sweden), NEMKO (Norway), DEMKO (Denmark) and EI (Finland) approved.
S	110V, 120V, 220V and 240V (Switchable)	General export model

This Service Manual is applicable the model SX-650/KCU.

CONTENTS

1.	SPECIFICATIONS	5
2.	FRONT PANEL FACILITIES	7
3.	CONNECTION DIAGRAM	9
4.	CIRCUIT DESCRIPTIONS	
4.1	Tuner Section	11
4.2	Phono Equalizer Amplifier	13
4.3	Microphone Circuit	14
4.4	Tone Control	14
4.5	Power Amplifier	14
4.6	Protection Circuit	15
4.7	Power Supply	16
5.	BLOCK DIAGRAM	17
6.	LEVEL DIAGRAM	19
7.	DISASSEMBLY	20
8.	DIAL CORD STRINGING	22
9.	PARTS LOCATIONS	
9.1	Front Panel View	23
9.2	Rear Panel View	25
9.3	Top View	27
9.4	Bottom View	29
9.5	Front View	31

10.	ADJUSTMENTS	
10.1	AM Section	33
10.2	FM Section	34
10.3	MPX Section	35
11.	EXPLODED VIEWS	
11.1	Exterior	37
11.2	Part 1 Dial Scale	39
11.3	Part 2 Dial Frame	40
11.4	Part 3 Tuner and AF Assembly	41
11.5	Part 4 Power Amplifier	42
11.6	Part 5 Power Transformer	43
11.7	Part 6 Power Amplifier	44
11.8	Part 7 Rear Panel	45
12.	SCHEMATIC DIAGRAMS, P.C. BOARD PATTERNS AND PARTS LIST	
12.1	Miscellaneous Parts List	46
12.2	Schematic Diagram	49
12.3	Tuner and AF Assembly (AWE-075)	51
12.4	Equalizer Amplifier Assembly (AWK-065)	58
12.5	Tone Control Assembly (AWG-049)	60
12.6	Power Amplifier Assembly 1 (GWH-101)	63
12.7	Power Amplifier Assembly 2 (GWR-101)	67
12.8	Headphone Assembly (AWX-106)	71
12.9	De-emphasis Switch Assembly (AWX-095)	72
12.10	Power Supply Assembly (AWR-117)	73
12.11	Tuner and AF Assembly (AWE-075-A)	75
13.	PACKING	82
ADDITIONAL SERVICE MANUAL		
1.	SPECIFICATIONS	84
2.	CONTRAST OF MISCELLANEOUS PARTS	84
3.	MODEL SX-650/HG	
3.1	Rear Panel	86
3.2	Schematic Diagram	87
3.3	Power Supply Assembly (AWR-118)	89
4.	MODEL SX-650/S	
4.1	Schematic Diagram	91
4.2	De-emphasis Switch Assembly (AWX-100)	93
4.3	Rear Panel	94

1. SPECIFICATIONS

Semiconductors

FET	1	ICs	7
Transistors	29	Diodes	29

Amplifier Section

Continuous Power Output from 20 Hertz to 20,000 Hertz.
(Both channels driven) 35 watts per channel (8 ohms)
35 watts per channel (4 ohms)

Continuous Rated Power Output . . . No more than 0.3%
18 watts per channel power

output, 8 ohms No more than 0.05%

1 watt per channel power

output, 8 ohms No more than 0.05%

Intermodulation Distortion (50Hertz: 7,000Hertz=4:1,
from AUX)

Continuous Rated Power Output . . . No more than 0.3%
18 watts per channel power

output, 8 ohms No more than 0.05%

1 watt per channel power

output, 8 ohms No more than 0.05%

Dumping Factor

(20 Hertz to 20,000 Hertz 8 ohms) 30

Input (Sensitivity/Impedance)

PHONO 2.5mV/50k ohm

MIC 7mV/50k ohms

AUX 150mV/50k ohms

TAPE PLAY 1 150mV/50k ohms

TAPE PLAY 2 150mV/50k ohms

TAPE PLAY 2 (DIN connector) . . . 150mV/50k ohms

PHONO Overload Level (T.H.D. 0.1%) . . . 200mV (1kHz)

Output (Level/Impedance)

TAPE REC 1 150mV

TAPE REC 2 150mV

TAPE REC 2 (DIN connector) 30mV/80k ohms

SPEAKER A, B, A+B

HEADPHONES Low Impedance

Frequency Response

PHONO (RIAA equalization) 30 Hertz to
15,000 Hertz ± 0.3 dB

AUX, TAPE PLAY 10 Hertz to
50,000 Hertz ± 1 dB

Tone Control

BASS +8dB, -7dB (100Hz)

TREBLE +7dB, -6dB (10kHz)

Filter

HIGH 6kHz (6dB/oct.)

Loudness Contour (Volume control set at -40dB

position) +6dB (100Hz), +3dB (10kHz)

Hum and Noise (IHF, short-circuited, A Network,

rated power)

PHONO 70dB

AUX, TAPE PLAY 90dB

FM Section

Usable Sensitivity	MONO	10.7dBf (1.9 μ V)
	STEREO	19.0dBf (4.9 μ V)
50dB Quieting Sensitivity	MONO	15.0dBf (3.1 μ V)
	STEREO	38.0dBf (44 μ V)
Signal to Noise Ratio at 65dBf	MONO	70dB
	STEREO	65dB
Distortion at 65dBf 100Hz . . .	MONO	0.15%
	STEREO	0.3%
1kHz . . .	MONO	0.15%
	STEREO	0.3%
6kHz . . .	MONO	0.4%
	STEREO	0.4%
Frequency Response	30Hz to 15,000Hz	± 0.2 dB
Capture Ratio		1.0dB
Alternate Channel Selectivity		60dB
Spurious Response Ratio		75dB
Image Response Ratio		65dB
IF Response Ratio		90dB
AM Suppression Ratio		50dB
Muting Threshold		14dBf (2.8 μ V)
Stereo Separation		40dB (1kHz)
		30dB (30Hz ~ 15kHz)
Subcarrier Product Ratio		62dB
SCA Rejection Ratio		62dB
Antenna Input		300 ohms balanced
		75 ohms unbalanced

AM Section

Sensitivity (IHF, Ferrite antenna)	300 μ V/m
(IHF, Ext. antenna)	15 μ V
Selectivity	35dB
Signal to Noise Ratio	50dB
Image Response Ratio	40dB
IF Response Ratio	65dB
Antenna	Built-in Ferrite Loopstick Antenna

Miscellaneous

Power Requirements	120V, 60Hz
Power Consumption	130W (UL), 310W (max.)
	240VA (CSA)
Dimensions	480(W)x140(H)x371(D)mm
	18-7/8(W)x5-7/8(H)x14-5/8(D)in.
Weight Without package	13.1kg (28 lb 13 oz)
With package	14.7kg (32 lb 5 oz)

Furnished Parts

FM T-type Antenna	1
Operating Instructions	1

NOTE:

Specifications and design subject to possible modification without notice, due to improvements.

2. FRONT PANEL FACILITIES

POWER INDICATOR LAMP

Lights when SPEAKERS switch is moved to any other position from POWER OFF, and AC power is supplied to the receiver.

SPEAKERS SWITCH

Functions as both power switch and speaker selection switch.

POWER OFF: AC power is off.

A: Sound will be heard from speakers connected to A speaker terminals.

OFF: No sound will be heard from speaker systems. This position should be used when listening with headphones.

B: Sound will be heard from speakers connected to B speaker terminals.

A + B: Sound will be heard from speakers connected to A terminals and from speakers connected to B terminals.

PHONES PLUG

Insert headphone plug into this jack when headphone listening is desired. In this case, SPEAKERS switch should be in OFF position.

BASS, TREBLE CONTROLS

When turned clockwise from the OFF position, response in bass or treble range, respectively, is boosted. Turning counterclockwise attenuates response. At the OFF position the tone control circuit is bypassed and frequency response is flat.

HIGH FILTER SWITCH

For high frequency noise due to scratches on the record, place switch in 6kHz position. This will provide 6dB/octave attenuation at frequencies above 6kHz. For normal operation switch should be in OFF (upper) position.

FM MUTING SWITCH

For selection of FM broadcasts, the switch should be in ON (upper) position. When switch is in the ON position, unpleasant interstation noise is suppressed. When signal strength is poor, it may not be possible to bring in the desired station if MUTING is ON. In this case, place it in the OFF (lower) position.

SIGNAL METER

For FM and AM reception, turn TUNING knob until needle of the SIGNAL meter is deflected a maximum to the right.

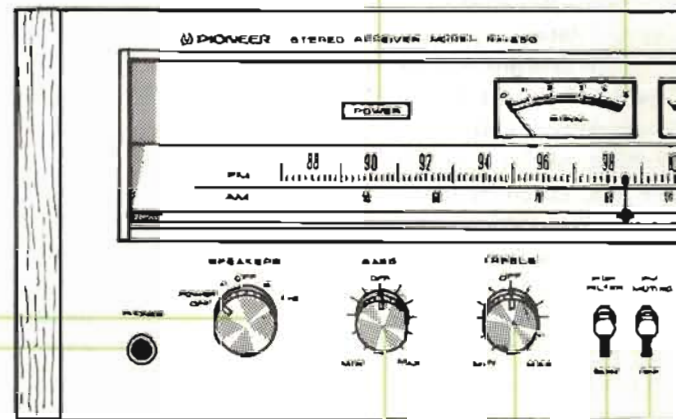

BALANCE CONTROL

For adjustment of relative output levels of L and R channels of speaker systems or headphones. Clockwise rotation from center position increases volume of R over L channel. Counterclockwise rotation increases volume of L channel over R.

VOLUME CONTROL

For adjustment of speaker or headphone output level. Level increases with clockwise rotation of the knob.

FM TUNING METER

With the needle of the SIGNAL meter deflected to the right, fine-tune FM broadcast by centering needle of the TUNING meter.

STEREO INDICATOR LAMP

Lights when FM stereo broadcast is being received.

TUNING KNOB

For selection of FM or AM stations.

FUNCTION SELECTOR

For selection of program source.

AM: AM broadcasts

FM: FM broadcasts

PHONO: Playing records

AUX/MIC: For use of component connected at AUX terminals of receiver, or microphone which may be plugged into MIC jack.

NOTE:

AUX and MIC program sources cannot be used simultaneously. When using AUX hi-fi component, microphone should be disconnected.

MIC JACK

Accepts standard 6mm ϕ plug. Microphone input signal enters both R and L channels.

TAPE MONITOR SWITCHES

1: For monitoring of playback or record mode of tape deck connected to TAPE 1 terminals (REC or PLAY).

2: For monitoring of playback or record mode of tape deck connected to TAPE 2 terminals (REC or PLAY).

NOTE:

When not monitoring record or playback mode of a tape deck, both switches should be in OFF (upper) position. If either 1 or 2 switch is in ON (lower) position, the program source selected by the FUNCTION switch will not be heard through speaker system or headphones.

MODE SWITCH

For selection of stereophonic or monophonic mode of playback. In normal operation, switch should be in STEREO position. In the MONO position, R and L channel signals will be mixed, and sounds coming from speakers of both channels will be the same.

NOTE:

Recording stereophonically with the MODE switch in the MONO position may cause channel separation to deteriorate.

LOUDNESS SWITCH

For listening at low volume level, placing this switch in the ON position will boost response in low and high frequency ranges.

The response of the human ear to low and high sound volumes is different. At low volume levels, the ear is relatively insensitive to sounds at either extreme of the frequency scale. By means of the LOUDNESS switch, these sounds are given additional amplification.

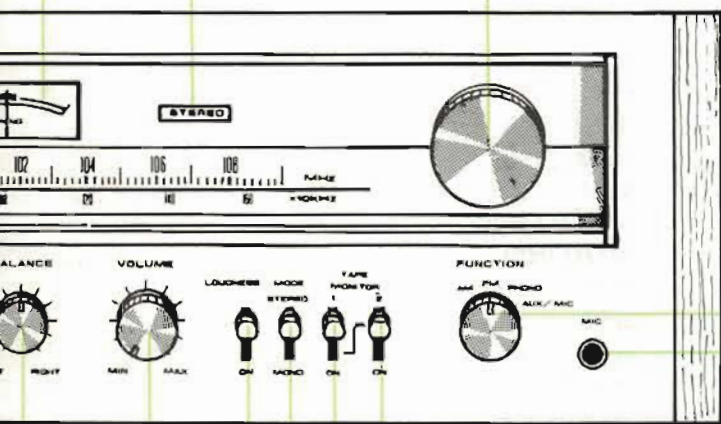

3. CONNECTION DIAGRAM

REAR VIEW

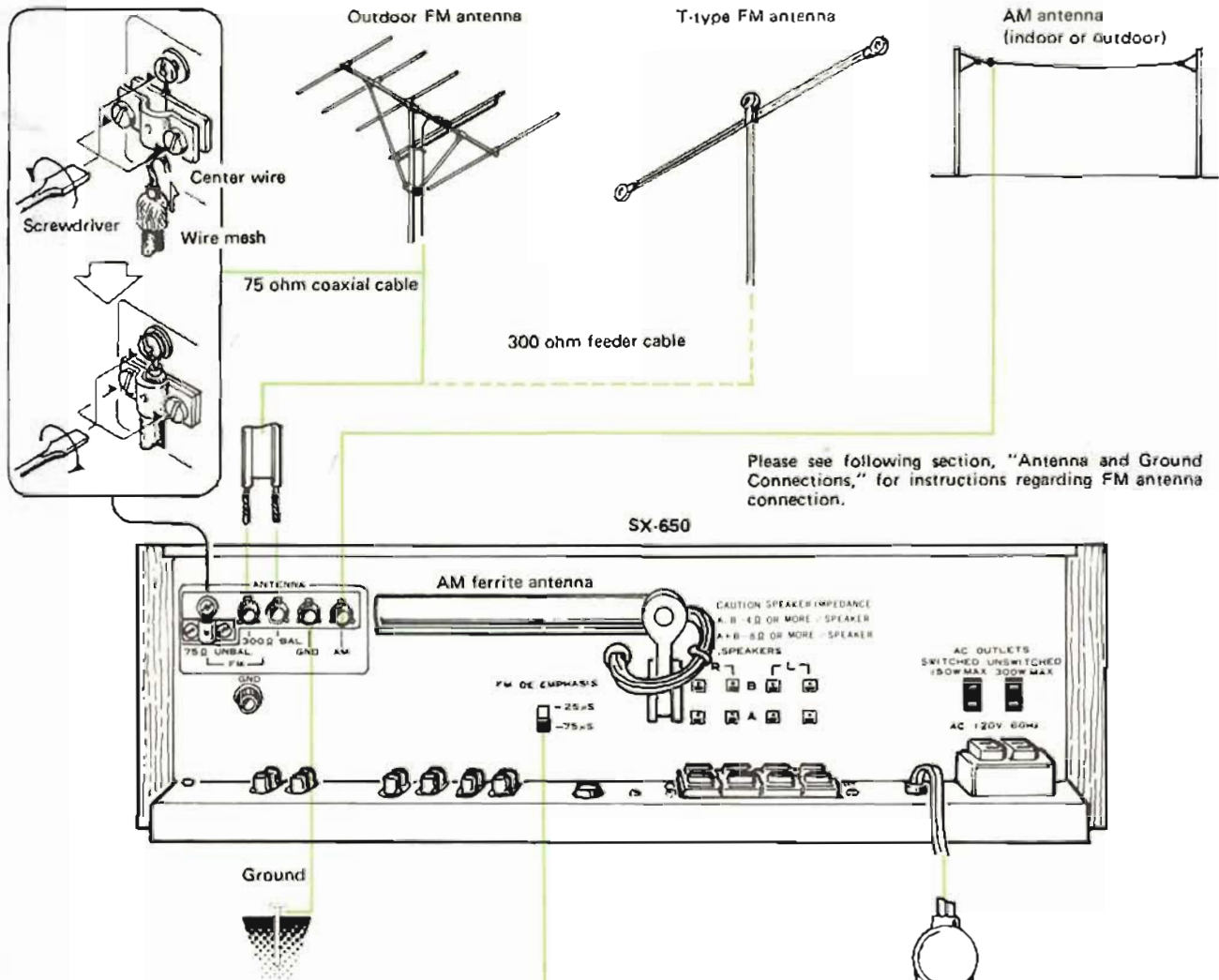

FM de-emphasis switch: For normal FM reception this switch should be set on "75μS" (unit is set to this when leaving factory). The "25μS" setting is used only when listening to FM Dolby™ transmissions. When listening to FM Dolby transmissions, it will be necessary to use an NR adaptor which can be purchased separately. More detailed instructions will be found in the section, "FM Dolby Reception."

ANTENNA PLACEMENT

Make note of the following points when choosing a location for the FM antenna.



Direction of signals

1.5 meters (5 ft.) above

More than 4 meters (15 ft.) above ground

- Feeder wire and cable should be insulated at mounting points.
- Length should be as short as possible.
- Feeder wire should not be coiled.

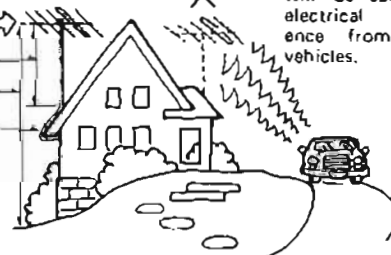

Antenna should not be placed where it will be subject to electrical interference from motor vehicles.

TOP VIEW

Accessory AC outlets:

Switched Power to this outlet is controlled by the SX-650 power switch. When power to the receiver is "ON", this outlet will provide AC current (150 watts maximum).

Unswitched Power to this outlet is not controlled by the SX-650 power switch. As long as the power cord is plugged into a live outlet, this outlet will supply AC current (maximum 300 watts).

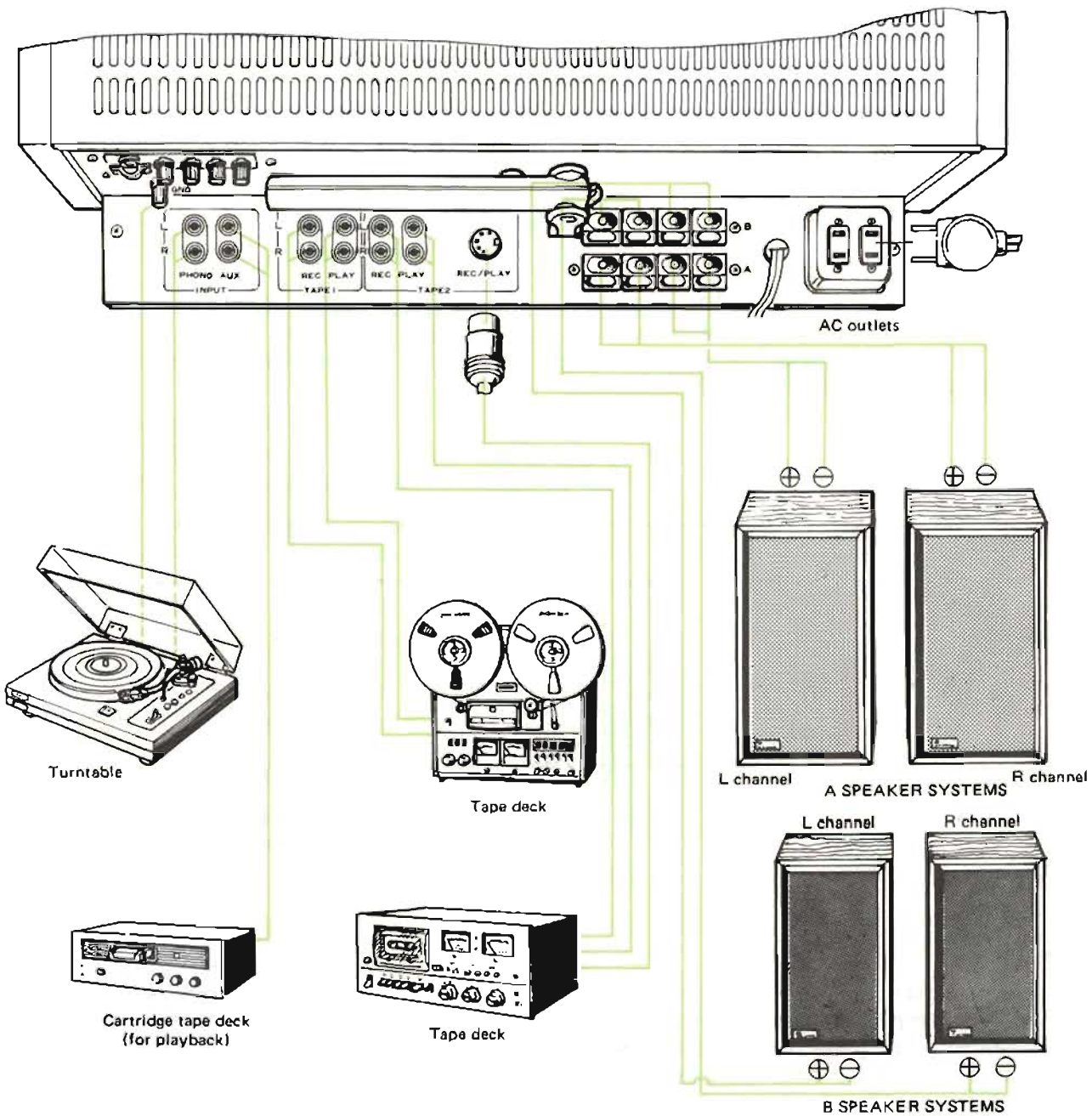

4. CIRCUIT DESCRIPTIONS

4.1 TUNER SECTION

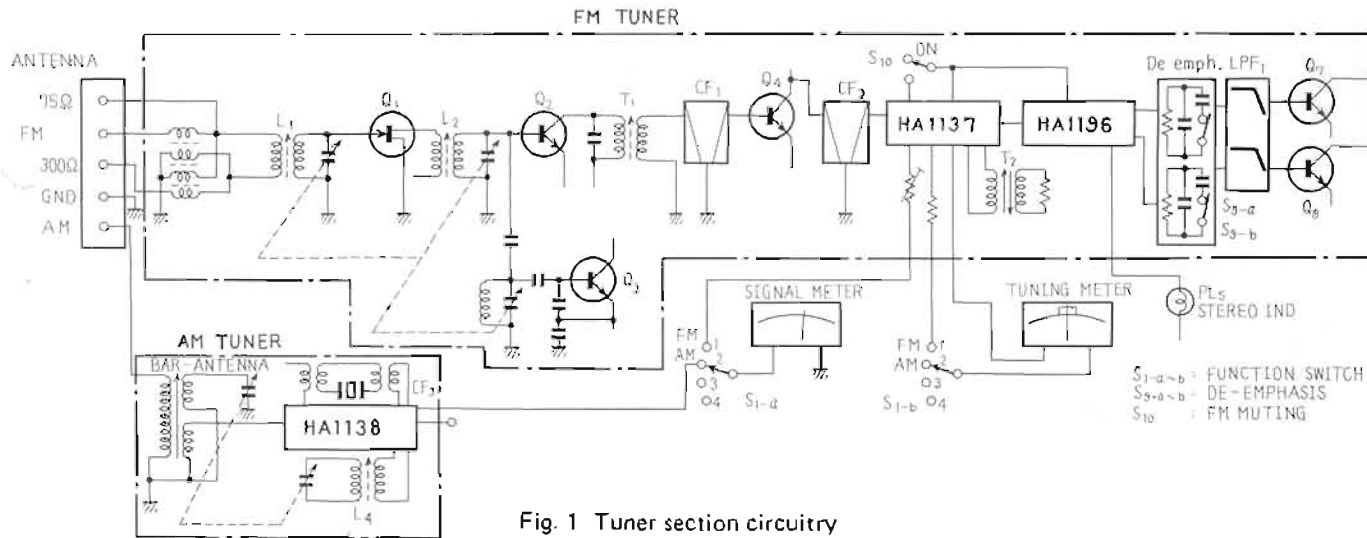

Fig. 1 Tuner section circuitry

AM Tuner

Composed of a single IC (HA1138) and single element ceramic filter, A 2-gang variable capacitor is employed with one stage providing tuning between the antenna and RF amplifier and the

other stage tuning the local oscillator. The RF amplifier itself is not tuned but feeds directly to the mixer followed by a 2-stage IF amplifier.

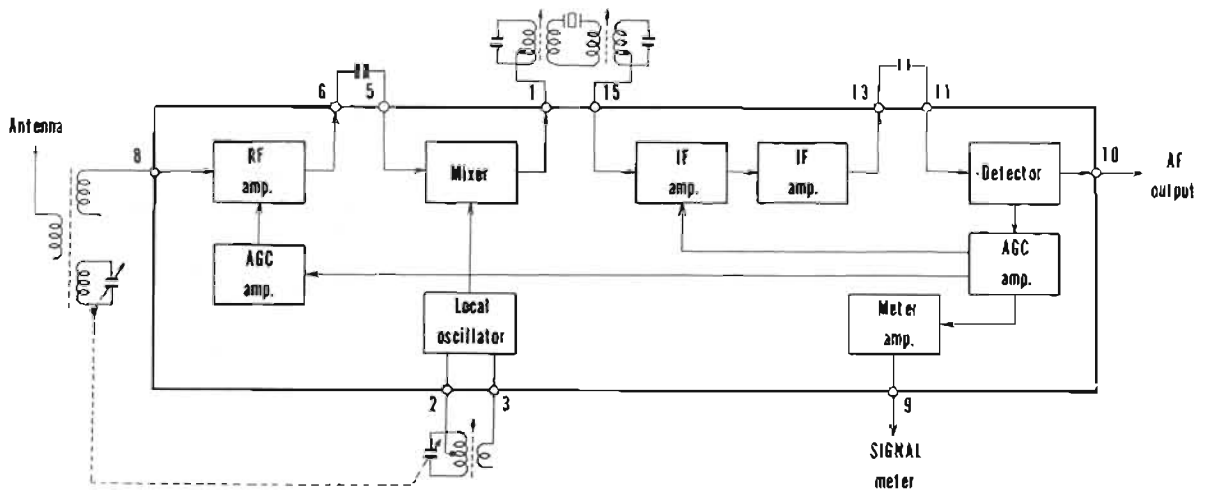

Fig. 2 HA1138 block diagram

FM Front End

A linear 3-gang variable capacitor is used in a single stage FET RF amplifier. The FET possesses high input impedance compared with a transistor, and allows simple coupling with the input tuning circuit, plus a significant advantage in terms of noise.

The local oscillator is a variation of a Clapp circuit and its excellent temperature compensation provides frequency stability even where no AFC is used. Local oscillator voltage is passed through a low value capacitor to the mixer transistor base.

FM IF Amplifier

This section consists of two dual element ceramic filters, an IC (HA1137) and a transistor. Ceramic filters possess excellent selectivity, which cannot be obtained with L-C type tuning filters. The circuit composition uses this quality to provide outstanding selectivity. Excellent sensitivity and S/N

ratio are also achieved by employing a transistor and a high density IC (HA1137). The HA1137 contains IF limiter amplifier, FM detector, meter drive and muting circuits.

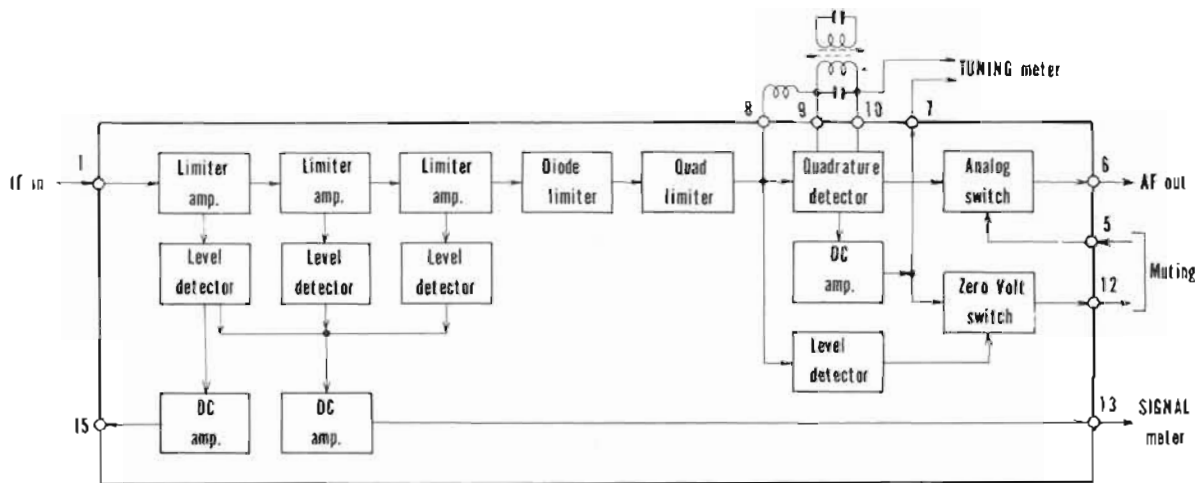

Fig. 3 HA1137 block diagram

Multiplex Decoder

Composed of three sections and employs an IC (HA1196) with a block diagram as shown in Fig. 4.

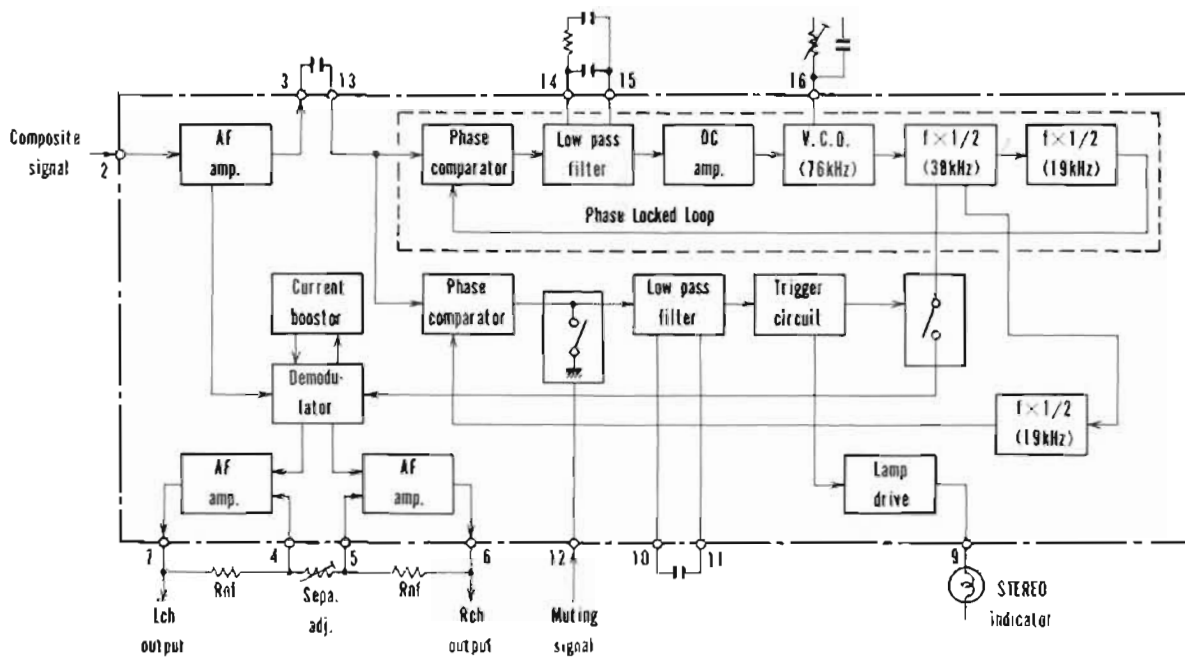

Fig. 4 HA1196 block diagram

1. Switching Signal Generator

A PLL (phase locked loop) system is employed. 76kHz is generated by the VCO (voltage controlled oscillator: an oscillator in which frequency is controlled by a voltage) and converted into 38kHz by a frequency divider, and then divided again to 19kHz. This signal and the stereo pilot component (19kHz) of the detected signal are applied to a phase comparator where the difference between them is converted into a voltage. By feeding this voltage back to the VCO, the oscillation signal is locked to the pilot signal.

This loop is termed PLL and a 38kHz switching signal synchronized to the pilot signal is obtained and employed as the switching signal.

2. Automatic Stereo Detector

Presence or absence of the pilot signal is detected by 19kHz obtained from the PLL and phase comparator. A voltage is then obtained at the phase comparator that is proportional to the pilot signal amplitude. This voltage operates a trigger circuit. If the pilot signal is present, the switching signal is applied to the demodulator and the Stereo indicator lights up. However, if the FM muting signal is also applied to pin 12, the detector circuit goes to ground. Therefore a switching signal to the demodulator is not supplied and mono reproduction is obtained.

3. Demodulator

This is a switching circuit employing two differential amplifiers (Fig. 5). The composite signal is applied to base of Q3. Q1 and Q2 are alternately switched ON and OFF by the switching signal.

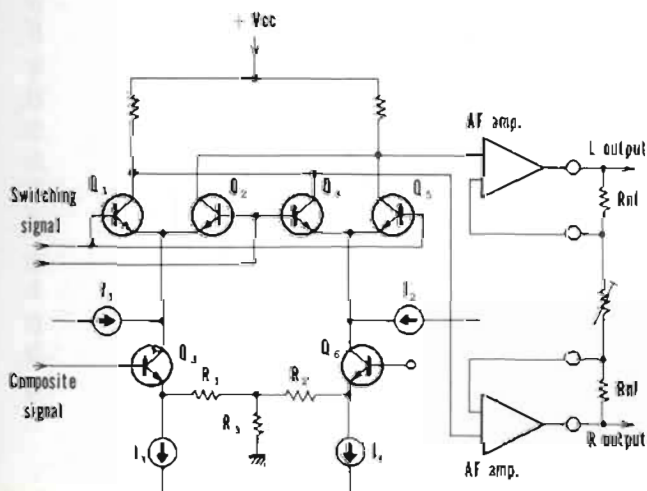

Fig. 5 Basic demodulator circuitry

The composite signal amplified at Q3 is demodulated by switching of Q1 and Q2. Q6 and Q3 are loosely coupled at their emitters by R1 - R3. Q6 is driven in opposite phase to Q3, the small composite signal is demodulated by switching of Q4 and Q5. The demodulated signals in opposite phase are composed with the collector of Q1 and Q2, crosstalk is cancelled.

Adequate current flow is required in Q3 and Q6 for low distortion. However, if the base bias voltage is raised, the voltage swing at the collector is reduced and clipping occurs (power supply voltage is limited by the IC voltage tolerance). For this reason, current from an external source is inserted at Q3 and Q6 collectors to become I1 and I2. The same currents are obtained as I3 and I4 from the emitters. Q3 and Q6 therefore operate with adequate current and distortion at this stage is remarkably reduced.

A feedback amplifier amplifies the demodulated signal to produce the IC output.

4.2 PHONO EQUALIZER AMPLIFIER

IC (TA7136P1) is used with independent left and right channels. Grade G styrene capacitors ($\pm 2\%$) and grade J metal film resistors ($\pm 5\%$) comprise the equalizer elements, yielding an RIAA deviation that is within 0.3dB from 30Hz to 15kHz.

NOTE:

Fig. 6-A shows the discrete component type while Fig. 6-B shows the IC type.

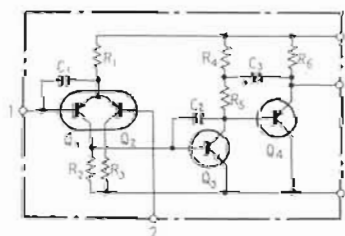

Fig. 6-A

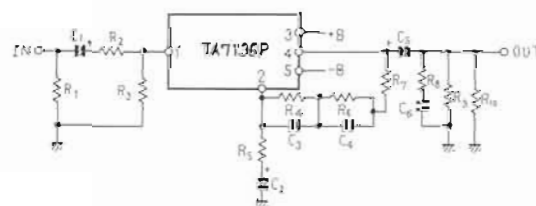

Fig. 6-B

Fig. 6 PHONO equalizer circuitry

4.3 MICROPHONE CIRCUIT

A single transistor amplifier (monophonic) is provided in addition to the phono equalizer amplifier. A selector switch cuts the AUX jack input when a plug is inserted into the MIC jack. The amplified microphone signal is then supplied to both left and right channels. The FUNCTION switch is set to the AUX position when using a microphone.

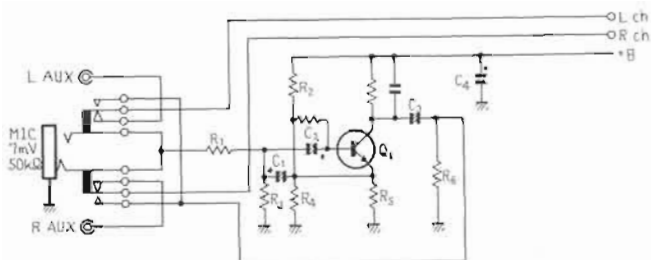

Fig. 7 Microphone circuitry

4.4 TONE CONTROL

CR type tone controls are connected to an amplifier with extremely low output impedance and flat response (IC TA7136, 31dB gain). Bass can be varied in the range of +8dB ~ -7dB (100Hz) and treble in the range of +7dB ~ -6dB (10kHz). Tone controls consist of a newly developed BASS and TREBLE pair. With the BASS control set at center position, the low frequency control circuit becomes a fixed loss circuit without regard to frequency. Signal flow to the high frequency control circuit will be absent when the TREBLE control is set to the center position and a flat frequency characteristic will be obtained.

NOTE:

Equivalent circuit shown in upper figure is obtained with controls at center.

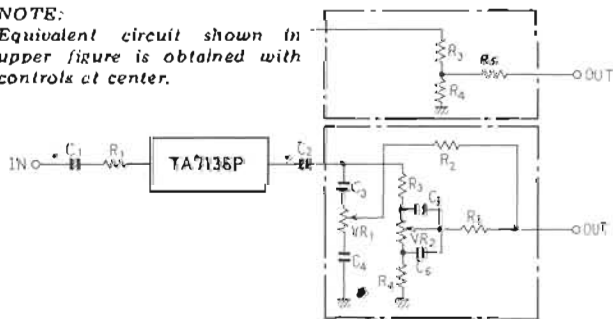

Fig. 8 Tone control circuitry

TREBLE VR

As shown in the Fig. 9 as slider A reaches the ultra-high resistance section (center position) of the resistor element, the VR becomes electrically open and signal flow ceases.

BASS VR

At center position (see Fig. 9) points A, B and C contact, shorting terminals 1, 2 and 4. Since terminals 3 and 4 are connected at the circuit board all terminals (1, 2, 3 and 4) become shorted.

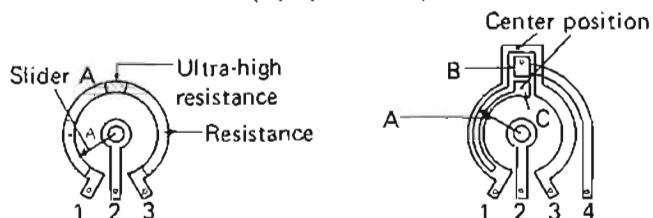

Fig. 9 TREBLE and BASS VR

4.5 POWER AMPLIFIER

This is a basic direct-coupled pure complementary OCL amplifier. Its operation is stabilized by the differential amplifier which is driven by a balanced power supply.

Q1, Q2 form a differential amplifier; 100% d.c. feedback is applied from the junction point of the power stage to the base of Q2 so the potential of the junction point is always maintained at the same level.

The driver and output stages are Darlington connected and a complementary symmetrical circuit is formed using a specially developed hybrid IC (Fig. 10). This ensures dynamic balance at different input levels.

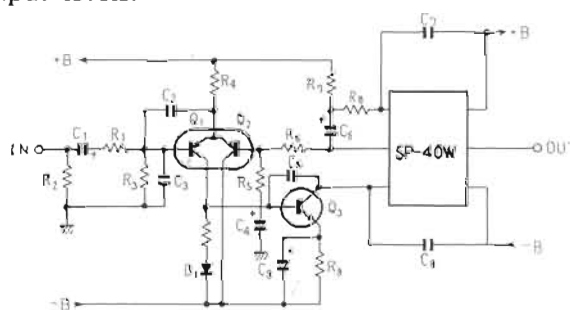

Fig. 10 Power amplifier circuitry

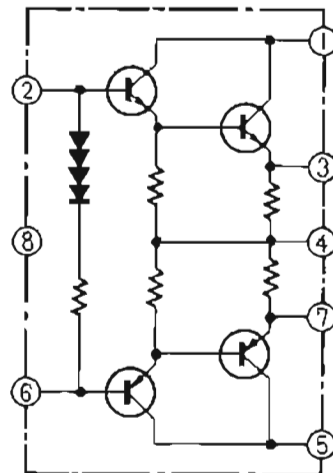

Fig. 11 SP-40W block circuitry

4.6 PROTECTION CIRCUIT

This circuit protects the power transistors in case of overload, the speakers in case of power amplifier malfunction, and also performs a muting function when the power supply is operated ON-OFF. The protection circuit is composed of three sections (Fig. 12).

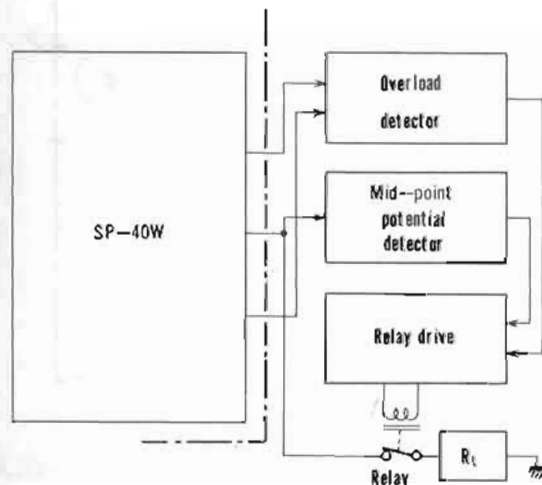

Fig. 12 Block diagram for protection circuitry

1. Relay Drive Circuit

The relay which connects the output circuits is driven by this circuit. It also performs a muting function to prevent unpleasant noise during ON-OFF operation of the power supply and cuts the output circuit on command from the detector circuit.

Muting Operation

When the power supply is set from OFF to ON, Q6 base is reverse biased through D6 and R19 - R21, turning Q6 OFF. Q7 base potential rises when C4 charges through R22 and R23, and Q7 turns ON several seconds later. The collector current of Q7 then flows through the relay coil, operating the relay to turn on the power amplifier output circuit. The reverse bias of Q6 base from D6 and R19 - R21 disappears when the power supply is set from ON to OFF. Q6 remains ON due to residual power supply voltage. C4 very rapidly discharges, Q7 base potential drops and Q7 becomes OFF. The relay releases and the power amplifier output circuit will be cut OFF.

NOTE:

Q5 is normally OFF due to base bias and does not participate in the muting operation.

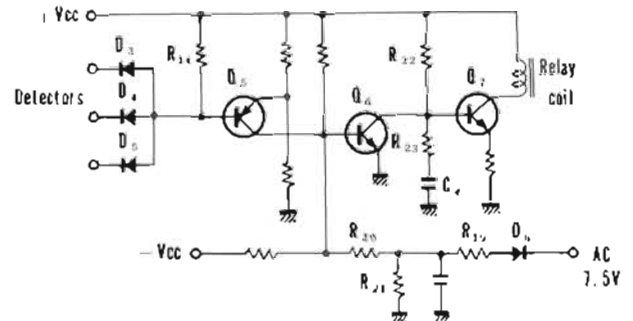

Fig. 13 Relay driver circuitry

Operation by Detector Circuit Command

Commands from the detector circuits pass through one of D3, D4 or D5 and are applied in the form of a current flow. Q5 is normally reverse biased through R14, but when a large current flows through one of these diodes, Q5 base potential declines according to the voltage drop at R14. Q5 then turns ON, Q6 base potential rises and Q6 switches ON. C4 rapidly discharges and Q7 base potential drops, turning Q7 OFF. The relay releases and the power amplifier output circuit will be cut off.

2. Overload Detector Circuit

Shorting of the power amplifier load or a load impedance below the specified value causes a command to be sent to the relay drive circuit. This operating principle is shown in Fig. 14. With the output stage in class B operation and Qa operating on the positive half cycle, Qb will be cut off and the signal current will flow as indicated by the solid arrows in Fig. 14. Point D potential at this time is the point A potential divided by R1 and R3. Also, point C potential is the point A potential divided by RE1 and RL (load). Point D is connected to Q1 base and point C to Q1 emitter through R2 and RE2.

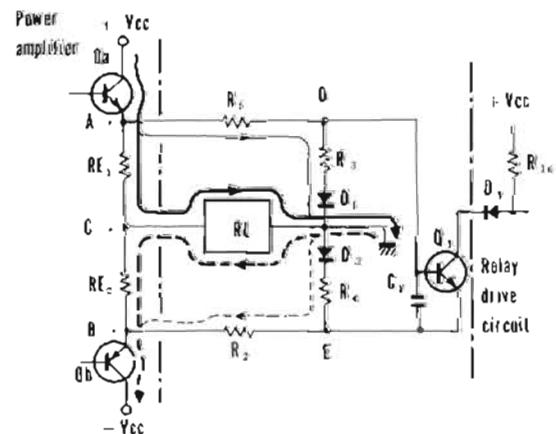

Fig. 14 Basic overload circuitry

When RL is extremely small, the point C potential will be considerably lower than point D. This potential difference forward biases Q1. Q1 switches ON and current flows in D3.

Qb operates in the negative half cycle and Qa cuts off. The signal flows as indicated by the broken line arrows in the center of Fig. 15. Q1 is biased by the potential difference between point C and point E. If RL is extremely small, the point C potential becomes considerably higher than that of point E. Q1 switches ON and current flows in D3. If large current flows in Qa and Qb, Q1 becomes ON by RE1 and RE2 voltage drop, and current flows in D3. C1 prevents faulty operation due to external noise.

MID-Point Potential Detector Circuit

If DC potential is produced at the junction point of the power amplifier, the command is sent to the relay drive circuit. Fig. 15 shows this operating principle.

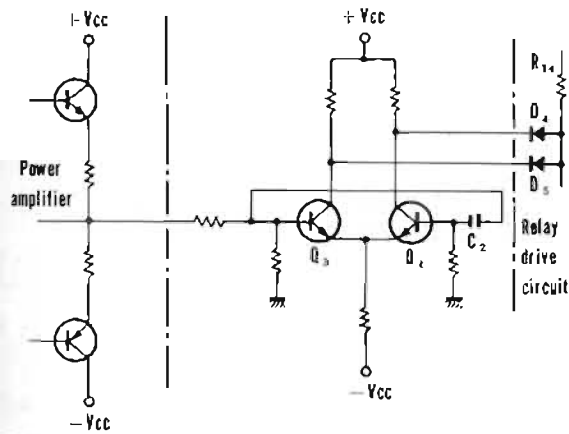

Fig. 15 Basic circuitry for mid-point potential detector

Q3 and Q4 comprise a differential amplifier. When the same input is applied to both input terminals (Q3 and Q4 bases), an output is absent. However, if there is a difference between the terminal inputs, the difference is amplified and becomes the output between the two collectors. During normal operation, an AC signal only is present at the junction point. As C2 reactance is sufficiently low, the same signal is applied to Q3 and Q4 bases, resulting in an absence of output at the collector sides. When a DC potential is produced at the junction point, it becomes the input of Q3 only. If the voltage is negative, Q3 collector current declines. And at Q4 the collector current increases and the potential drops, causing current to flow through D4.

If the DC voltage is positive, Q3 collector current increases and the potential drops, while at Q4 the collector current decreases and potential rises. Current therefore flows through D5.

4.7 POWER SUPPLY

Two windings are provided in the power transformer secondary and each is separately bridge rectified. One of these is sent as $\pm 96VDC$ to the voltage stabilizer circuit to become 13V, 33V and $-34V$ regulated voltages for supply to each assembly.

The other secondary voltage is bridge rectified and becomes $\pm 36V$ for supply to the power amplifier power(IC) stage. Extremely low power supply impedance is maintained by a 8,000 μF electrolytic capacitor.

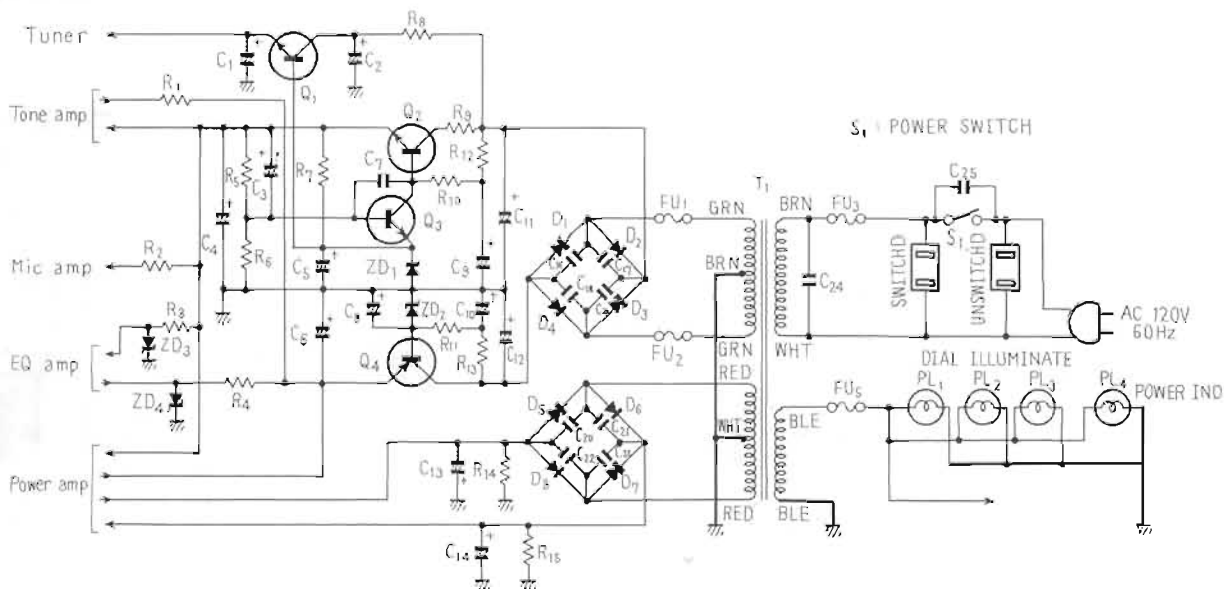
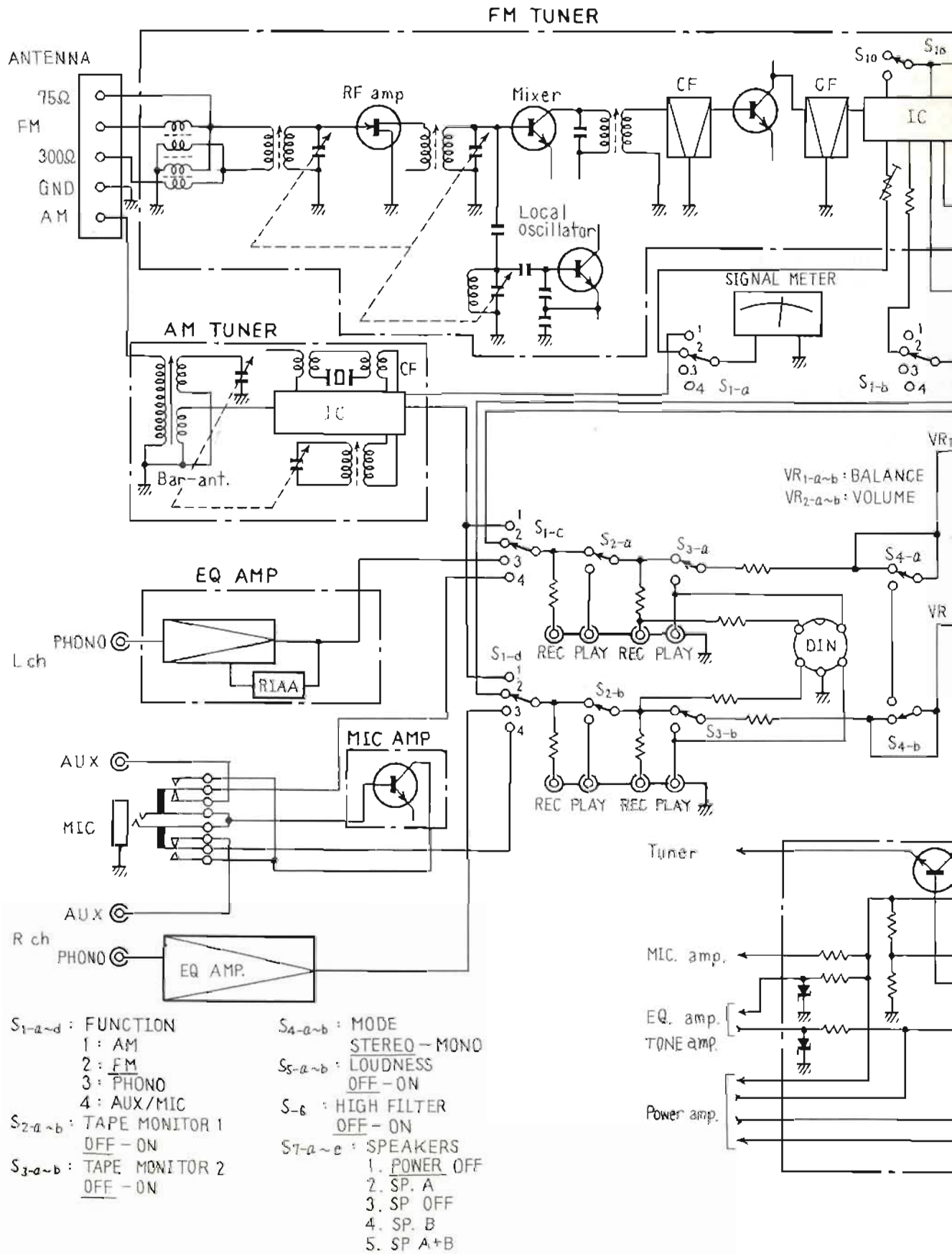
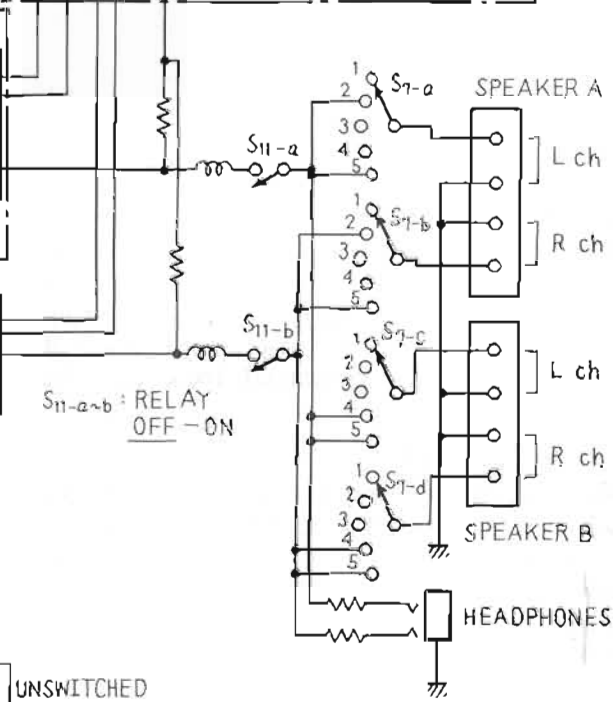
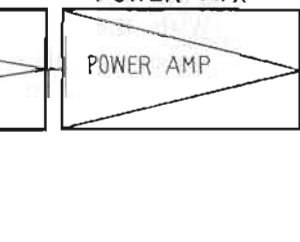
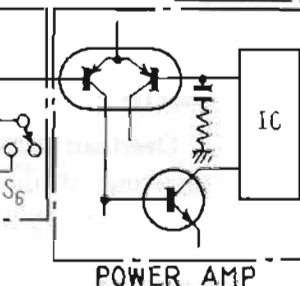
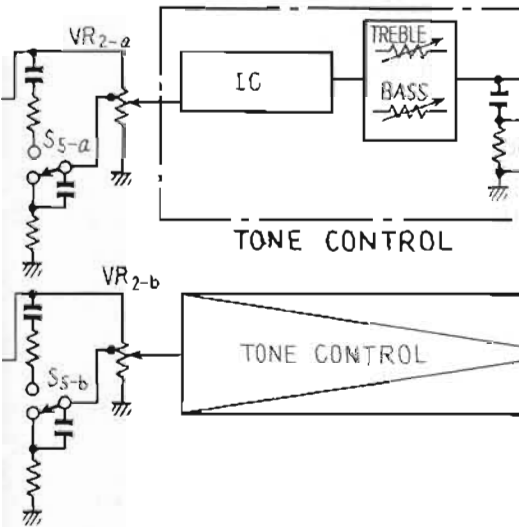
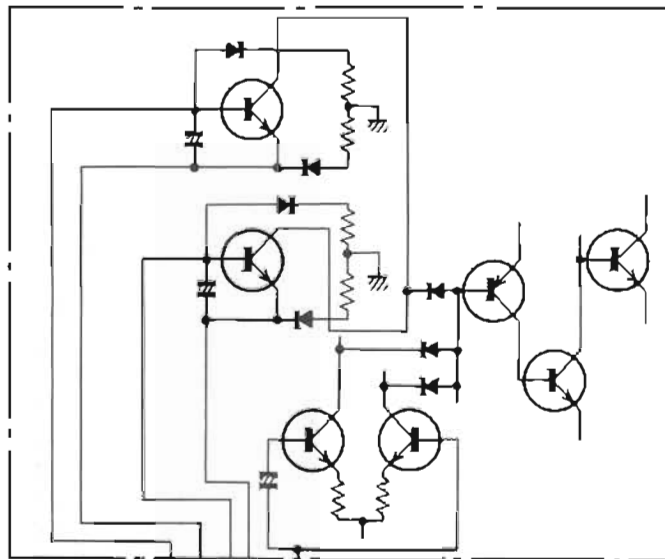
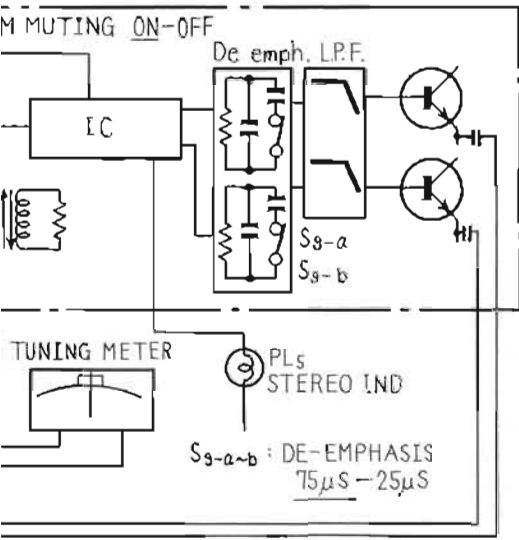

Fig. 16 Power supply circuitry

5. BLOCK DIAGRAM



PROTECTION CIRCUIT



POWER SUPPLY

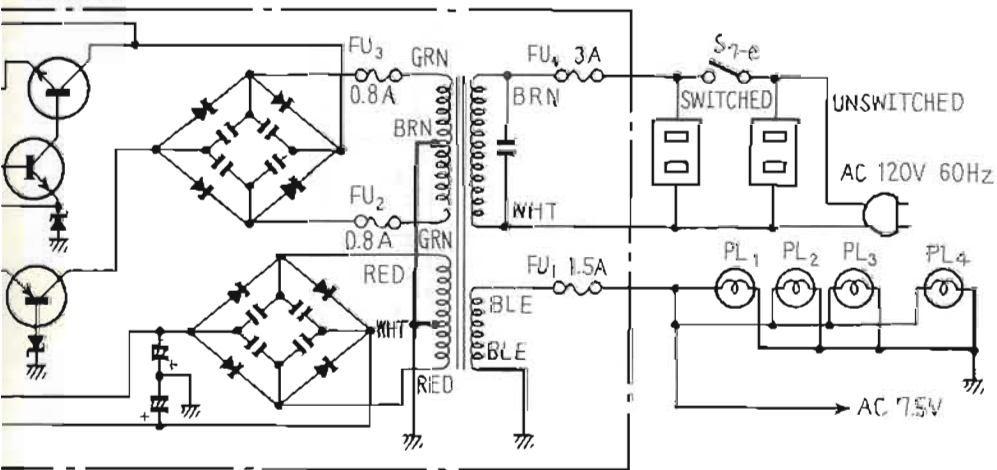

PL_{1~3} : DIAL ILLUMINATE
PL₄ : POWER IND.

6. LEVEL DIAGRAM

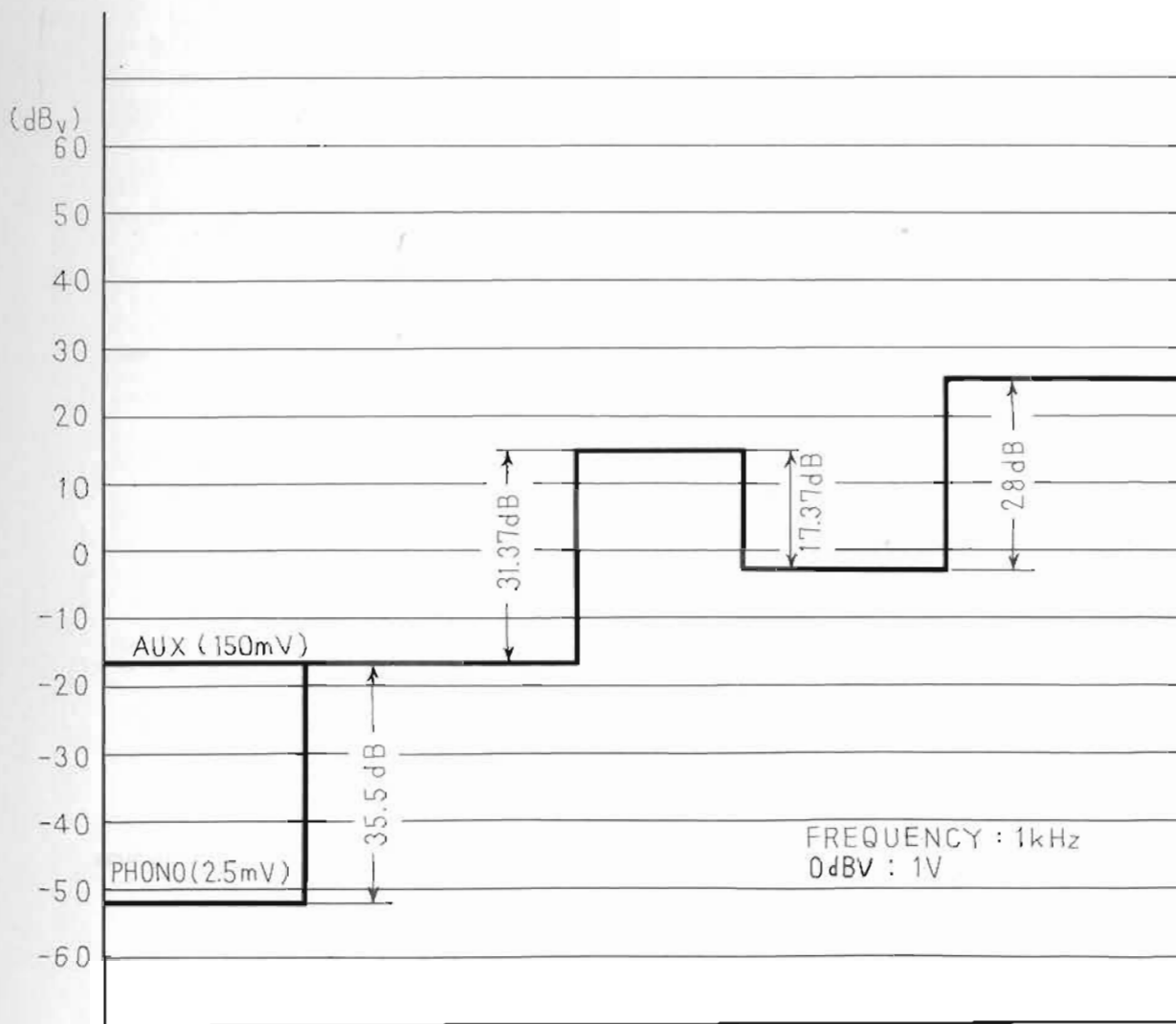
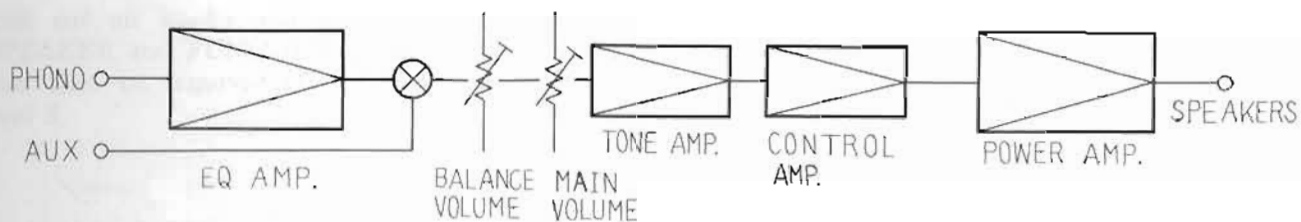

7. DISASSEMBLY

TOP COVER

To remove take out 2 screws on both left and right sides (total of 4 screws).

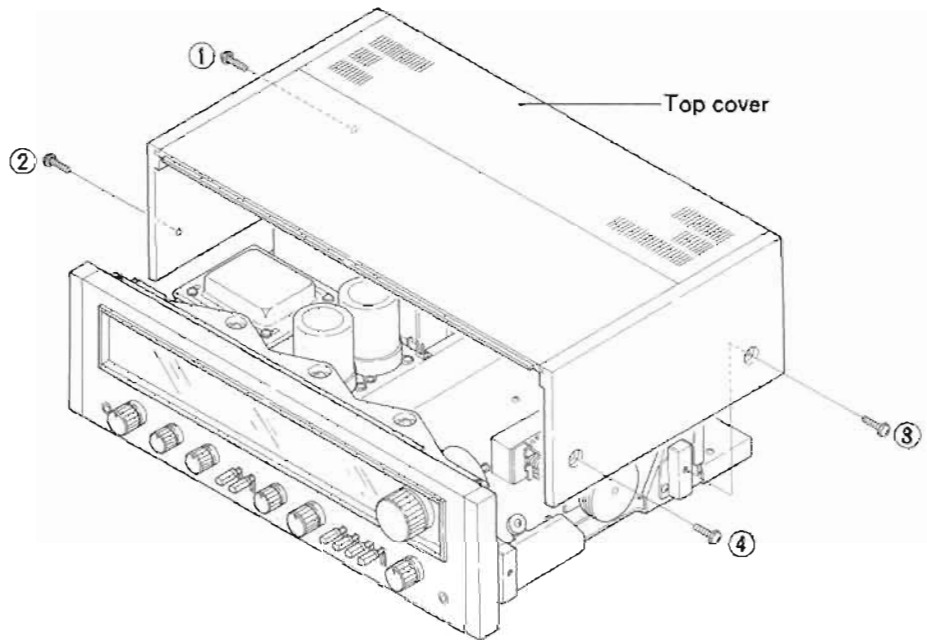

BOTTOM PLATE

To remove take out screws 1 – 11.

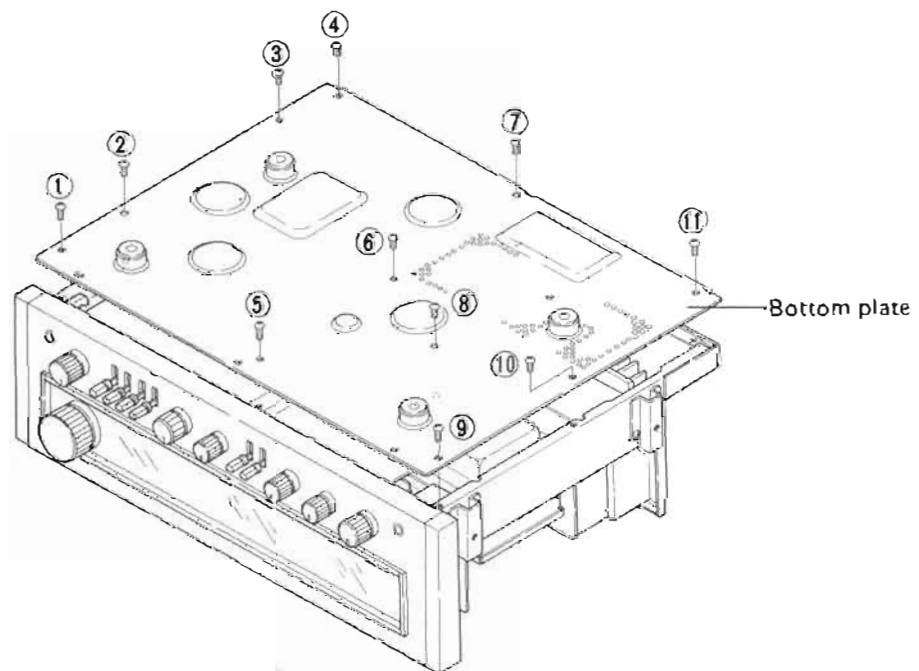

FRONT PANEL

Pull off all knobs and remove shaft nuts on SPEAKER and FUNCTION switches. Front panel can then be removed after taking out screws 1 and 2.

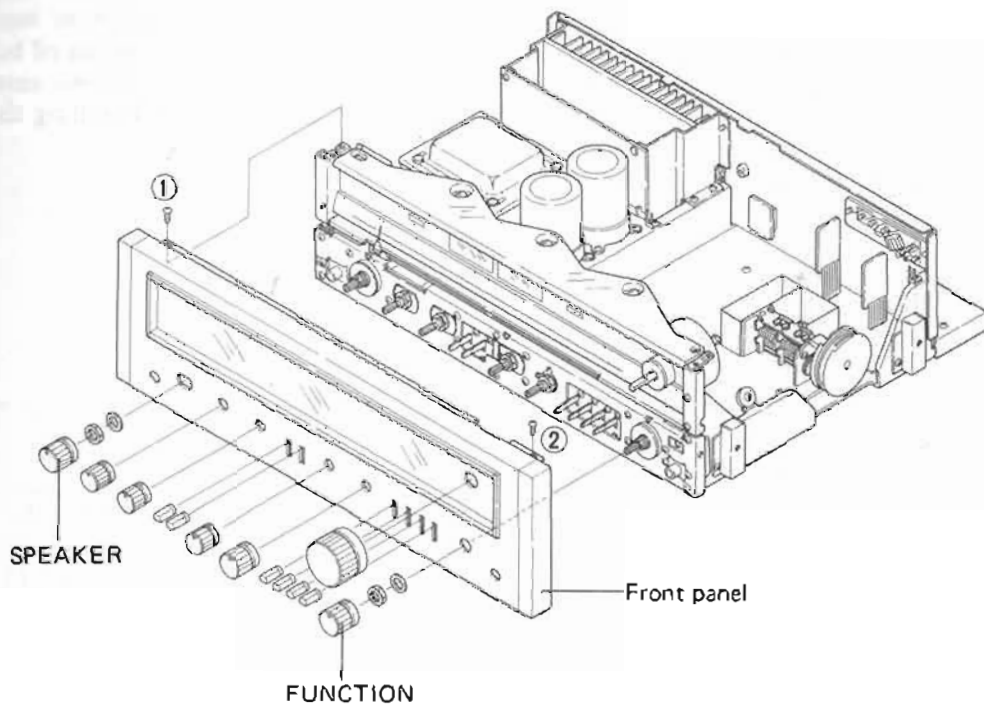

8. DIAL CORD STRINGING

1. Remove the wooden cover and the front panel.
2. Turn tuning drum fully clockwise (as viewed from X direction in Fig. 17).
3. Tie on end of cord to stud on inner section of tuning drum (more easily performed by loosening setscrew and temporarily removing tuning drum from shaft).
4. Route cord through tuning drum cutout, make a half turn around the drum, then route in sequence to pulley A-dial pointer-pulley B-pulley C.
5. Wind cord 3 turns clockwise (as viewed from the rear) around tuning shaft, then route to pulley D.
6. Wind cord two turns around tuning drum and tie to spring hook so that tension is applied to the cord.

7. Turn TUNING knob and confirm normal cord motion, then trim off excess cord.
8. With tuning capacitor blades fully closed, move dial needle to starting point (left edge of scale).
9. Apply laquor to tied ends of cord.

DIAL POINTER INSTALLATION CAUTION

Metal portion of dial pointer is plated. If this section is touched directly with the hand and collects fingerprints or other impurities, it is difficult to remove them from aventurine finish. As this is not desirable in terms of both appearance and anticorrosion, take extreme care not to touch the metal section when handling the dial pointer.

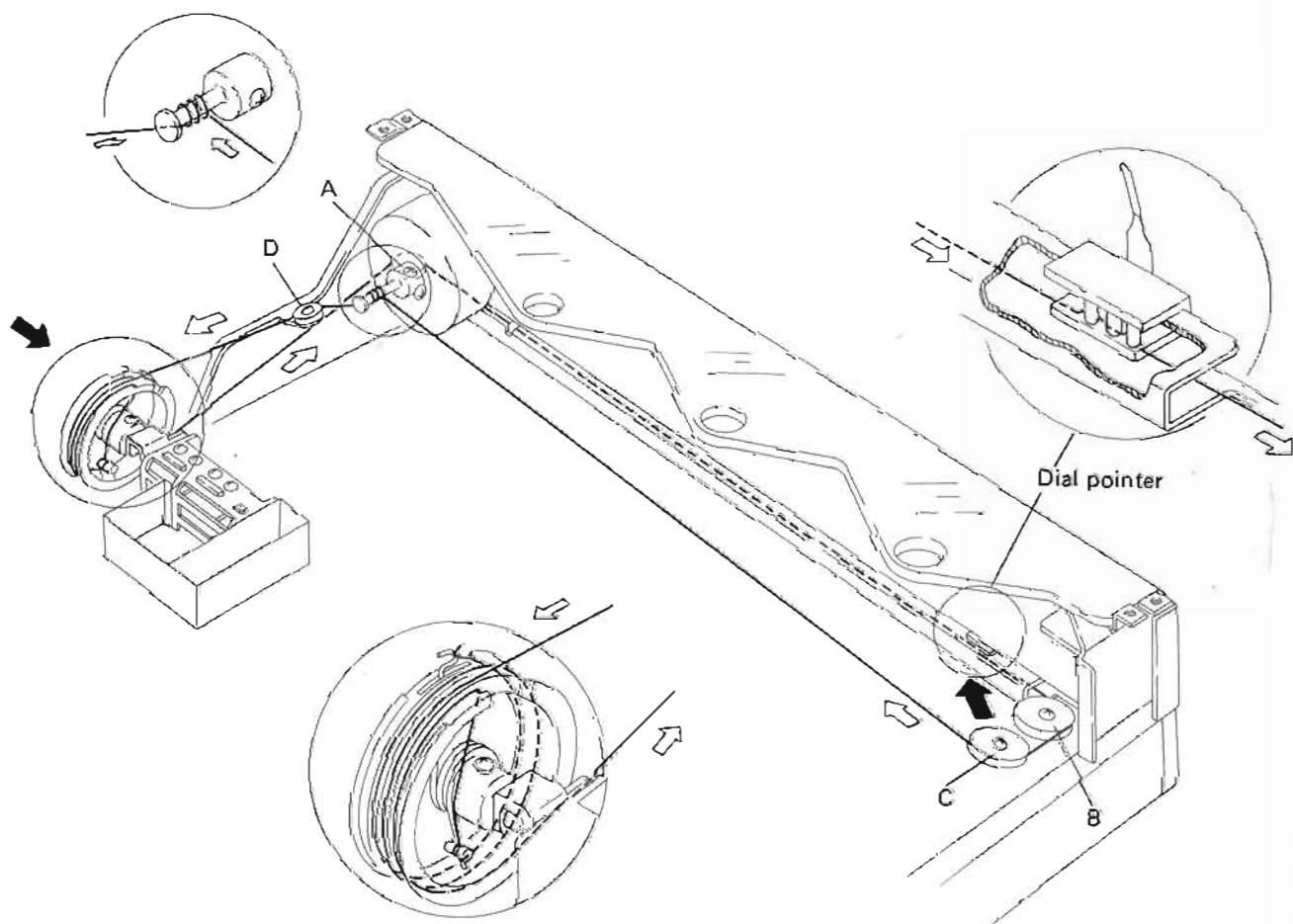

Fig. 17

9. PARTS LOCATIONS

9.1 FRONT PANEL VIEW

Wooden cabinet
AMM-053

Front panel assembly
ANB-444

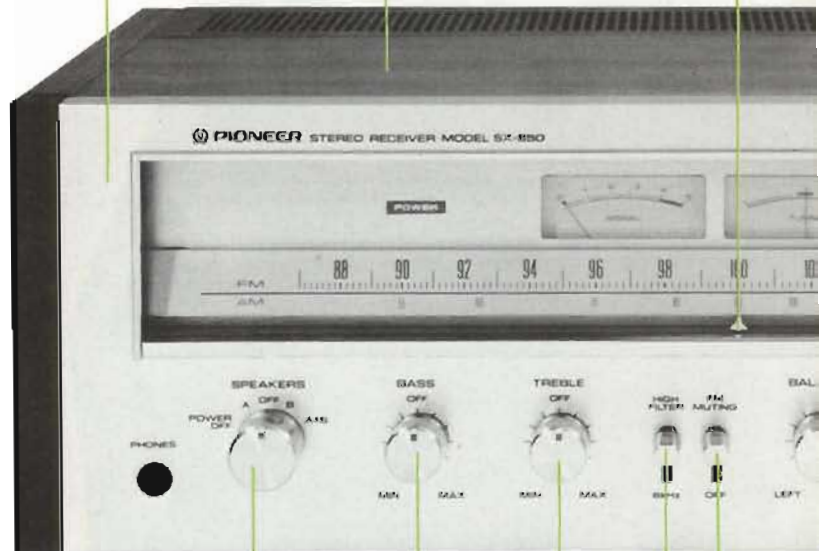

Knob (SPEAKERS)
AAB-100

Knob (BASS)
AAB-099

Knob (TREBLE)
AAB-099

Knob (HIGH FILTER)
AAD-113

Knob (FM MUTING)
AAD-113

9. PARTS LOCATIONS

9.1 FRONT PANEL VIEW

Wooden cabinet
AMM-053

Front panel assembly
ANB-444



Knob (SPEAKERS)
AAB-100

Knob (BASS)
AAB-099

Knob (TREBLE)
AAB-099

Knob (HIGH FILTER)
AAD-113

Knob (FM MUTING)
AAD-113

9.2 REAR PANEL VIEW

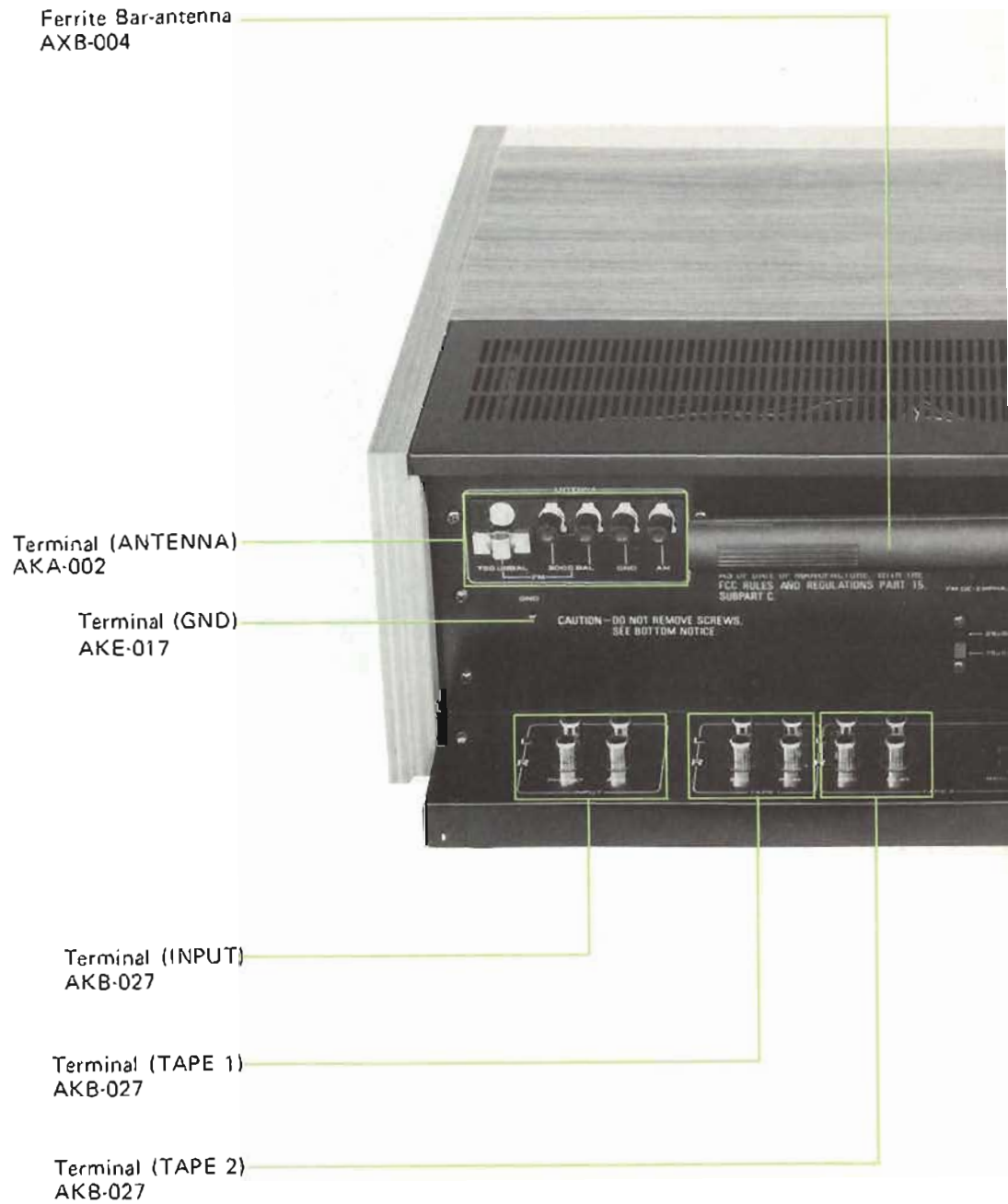



AC socket (AC OUTLET)
AKP-004

AC cord
ADG-005

Cover
ANF-379

Terminal (SPEAKER)
AKE-029

DIN connector socket
AKP-011

9.3 TOP VIEW

Power amplifier assembly 2
GWR-101

Power transformer
ATT-315 (MODEL KC)
ATT-303 (MODEL KU)

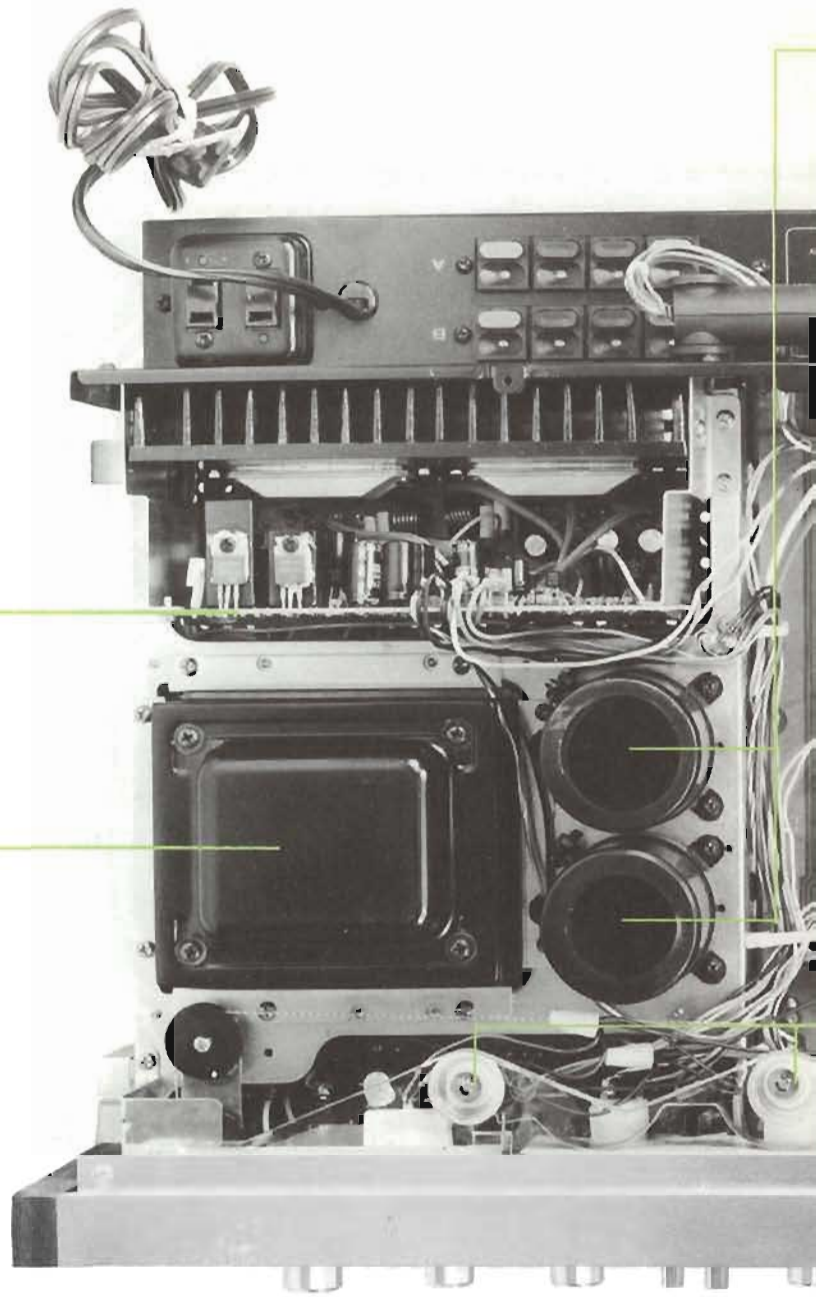

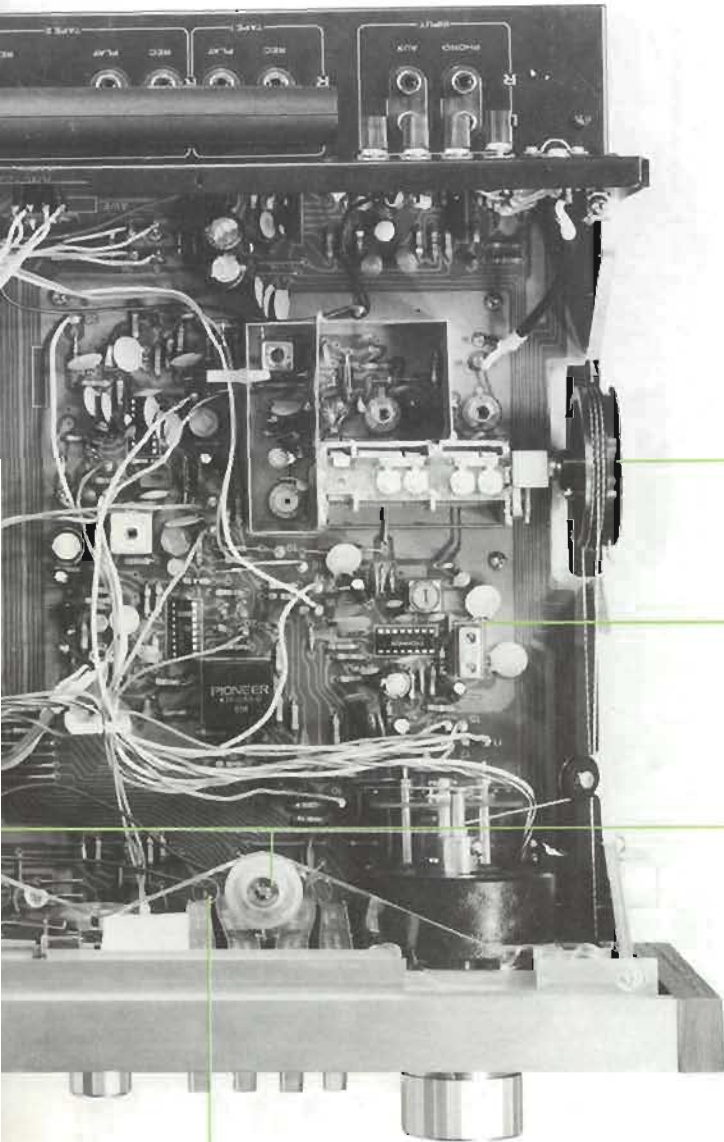

Electrolytic capacitor
ACH-071

Tuning drum assembly
AXA-070

Tuner and AF assembly
AWE-075

Lamp assembly
AEL-060

Dial scale plate
AEC-251

9.4 BOTTOM VIEW

Tuner and AF assembly
AWE-075

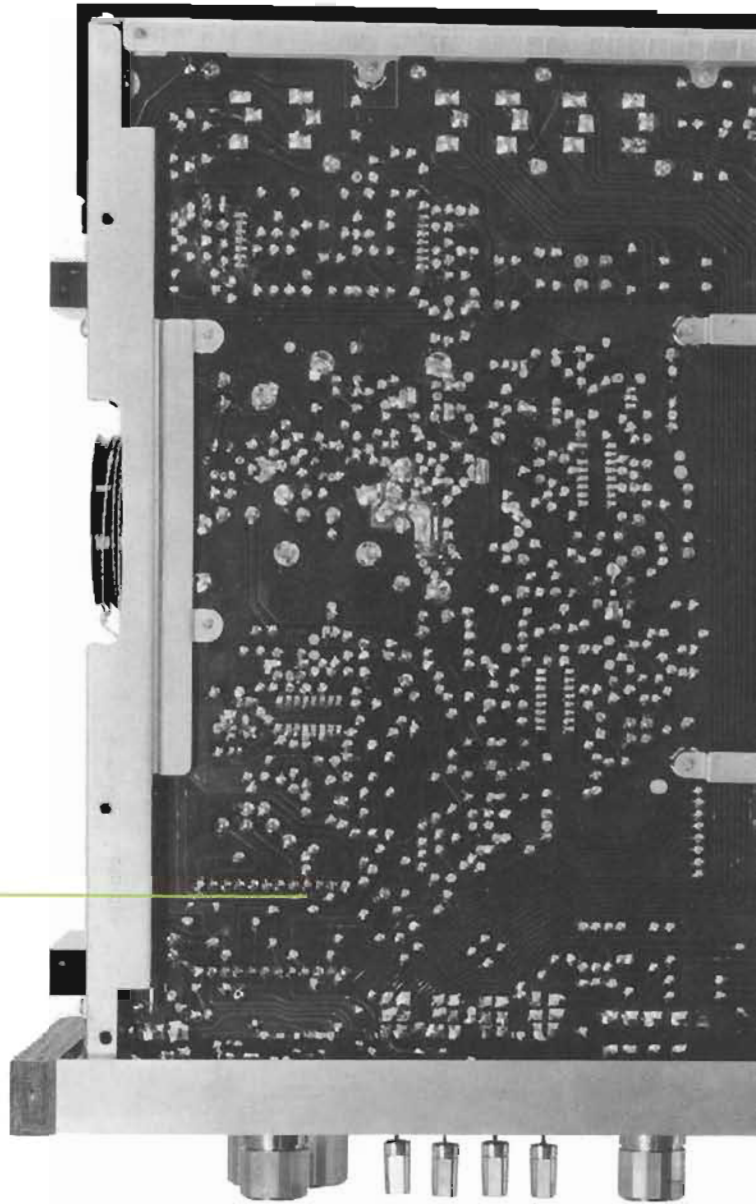

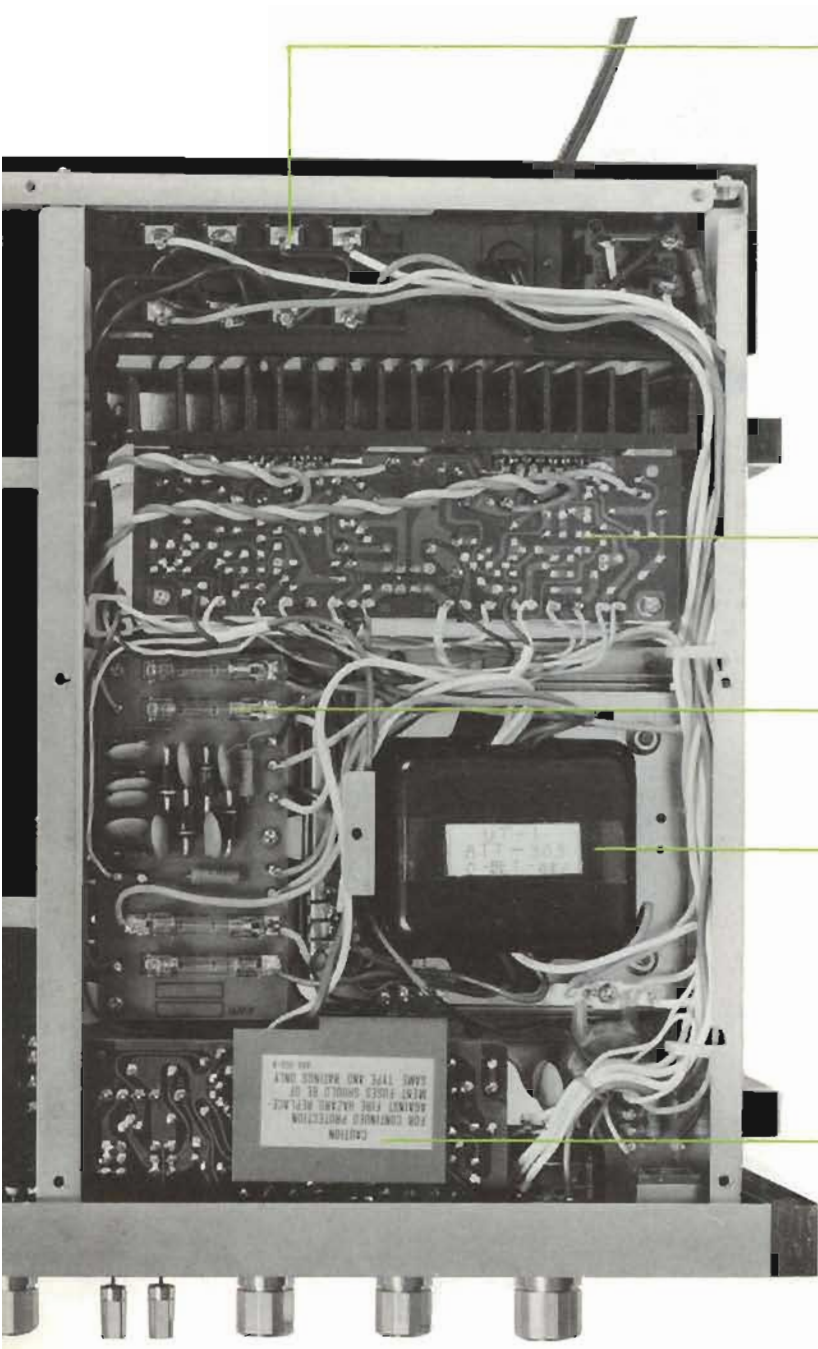

Terminal (SPEAKER)
AKE-029

Power amplifier assembly 1
GWH-101

Power supply assembly
AWR-117

Power transformer
ATT-315 (MODEL KC)
ATT-303 (MODEL KU)

Slide cover
ANH-298

CAUTION
FOR CONTINUED PROTECTION
AGAINST FIRE HAZARD REPLACE
FUSES WITH SAME TYPE AND RATING ONLY
DO NOT REMOVE FUSES UNTIL
POWER IS OFF

9.5 FRONT VIEW

Meter
AAW-040

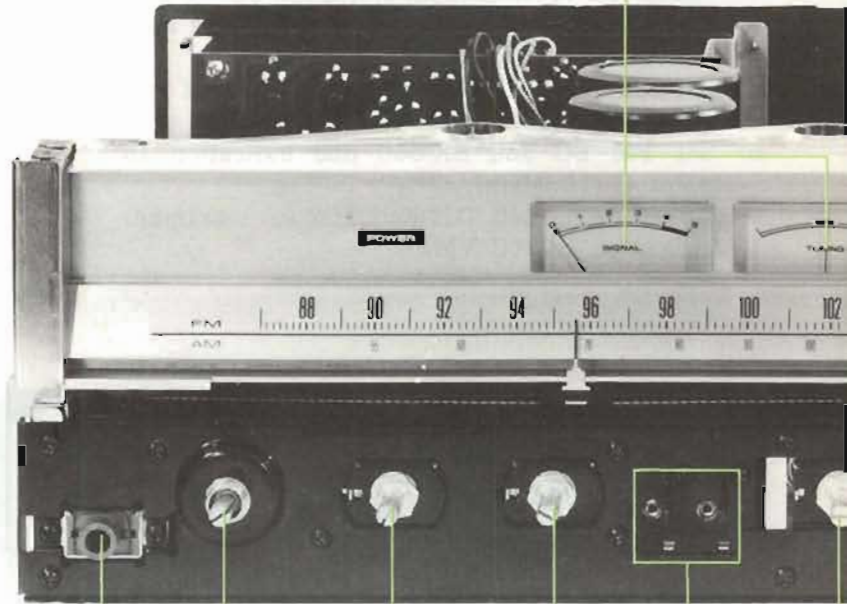

Phone jack (PHONES)
AKN-009

Rotary switch (SPEAKER)
ASA-039

Variable resistor (BASS)
ACV-159

Variable resistor (TREBLE)
ACV-160

Lever switch
(HIGH FILTER, FM MUTING)
ASK-090

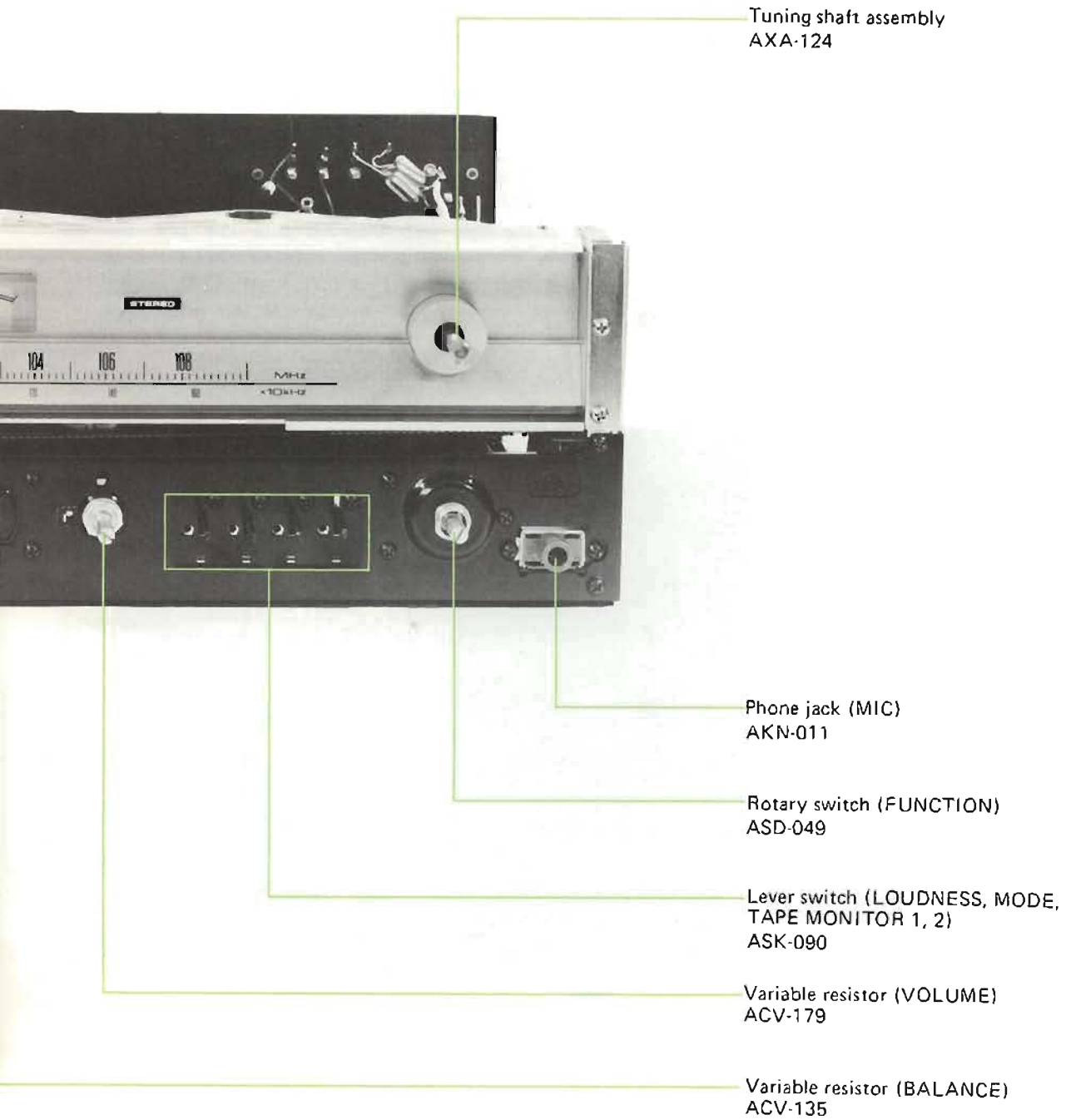

10. ADJUSTMENTS

10.1 AM SECTION

1. Through a 1kilo ohm resistor, connect an AM signal generator to the AM antenna terminal.
2. Connect AC voltmeter to TAPE REC jack (L or R).
3. Set FUNCTION switch to AM position.
4. Set AM SG and SX-650 dial indication to point A (600kHz).
5. Adjust L4 for maximum indication on AC VM.
6. Set AM SG and SX-650 dial indication to point C (1,400kHz).
7. Adjust TC4 for maximum indication on AC VM.
8. Again set AM SG and SX-650 dial indication to point A.
9. Adjust bar antenna core for maximum indication on AC VM.
10. Return AM SG and SX-650 dial indication to point C.
11. Adjust TC5 for maximum indication on AC VM.
12. Repeat steps 4-11 to eliminate variations in AM VM indications at points A and C.

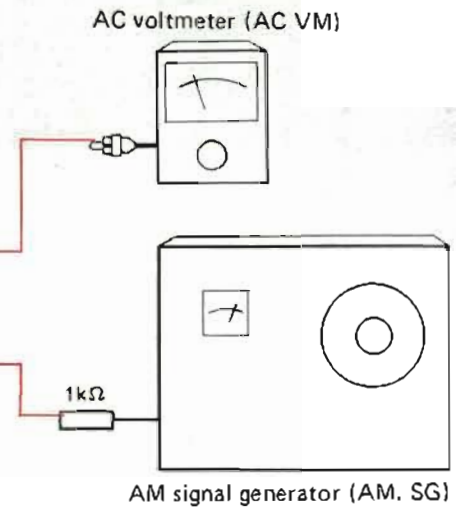
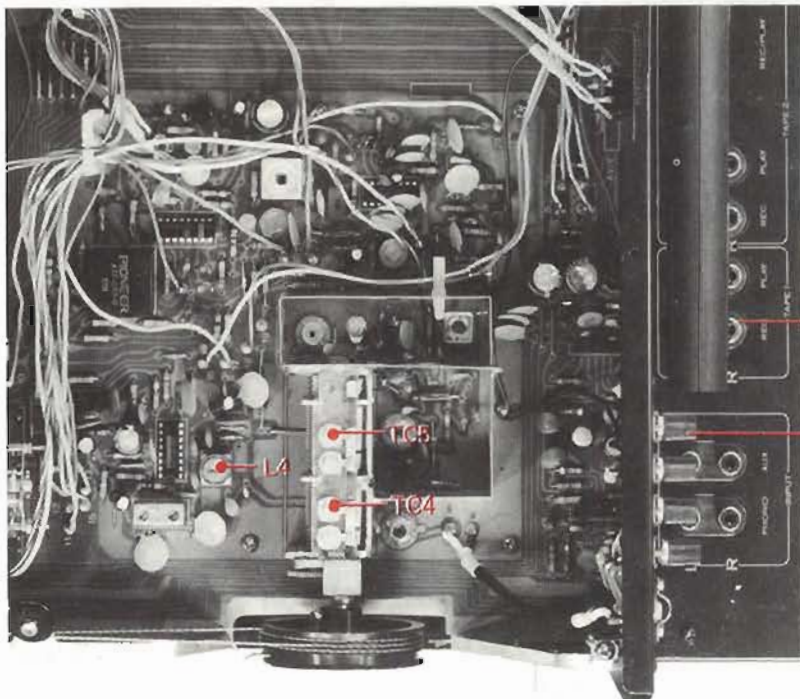

10.2 FM SECTION

1. Through 300 ohm dummy antenna, connect FM signal generator to 300 ohm FM antenna terminals and set for 400Hz at 100dB and 100% modulation.
2. Connect AC voltmeter and distortion meter to TAPE REC jack (L or R).
3. Set FUNCTION switch to FM and MUTING switch to OFF.
4. Set FM SG and SX-650 dial indication to point A (90MHz).
5. Adjust L3 for maximum indication on AC VM.
6. Adjust T2 lower core for center of scale indication on tuning meter.
7. Set FM SG for 9dB output and adjust L1 and L2 for maximum indication on AC VM.
8. Set FM SG and SX-650 dial indication to point C (106MHz).
9. Adjust TC3, then TC1 and TC2 for maximum indication on AC VM.
10. Again set FM SG and SX-650 dial indication to point A.
11. Adjust L3, then L1 and L2 for maximum indication on AC VM.
12. Repeat steps 8-11 to eliminate variations in sensitivity at point A and C.
13. Adjust T1 for maximum sensitivity.
14. Detune to noise only and adjust T2 lower core for center of scale indication on tuning meter.
15. Set SX-650 dial indication to point B (98MHz) and adjust FM SG for center to scale indication on tuning meter.
16. Set FM SG output to 60dB and adjust T2 upper core for minimum distortion.
17. Repeat steps 14-16 to eliminate variations in minimum distortion position.
18. Set FM SG for 100dB output and adjust VR3 so that the signal meter indicates 4.6 on the scale.

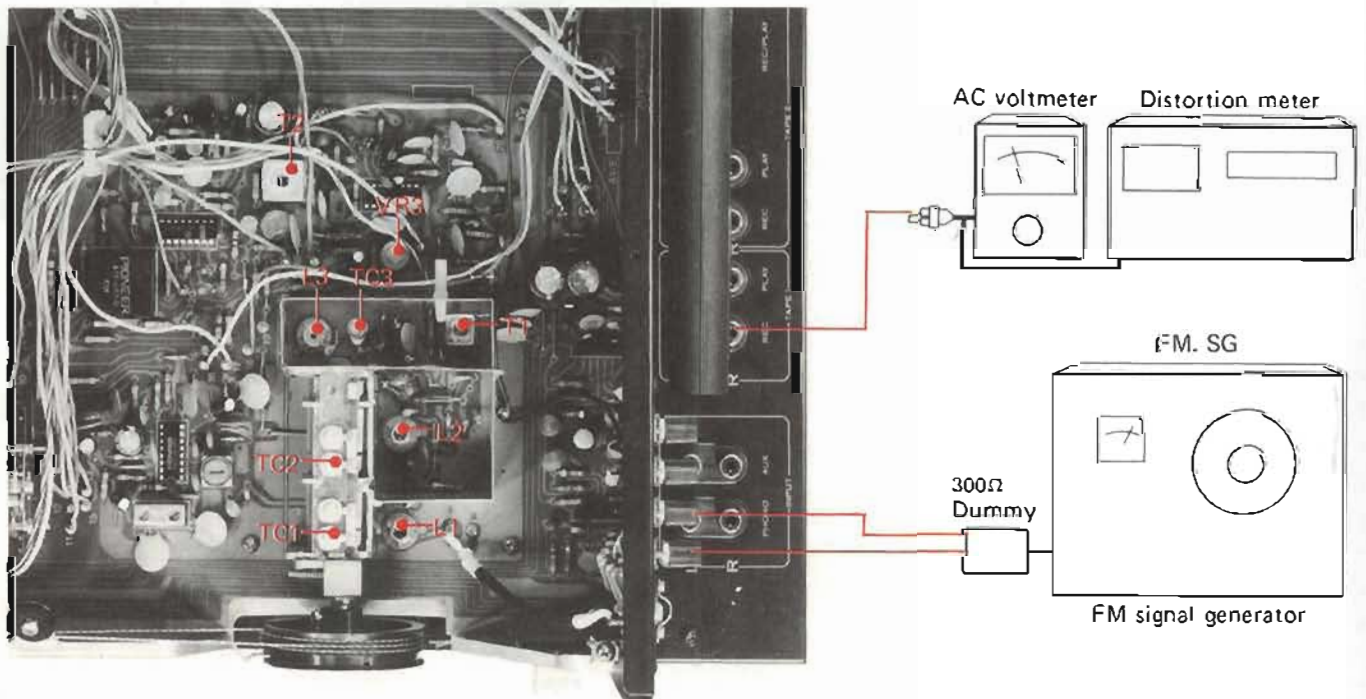

10.3 MPX SECTION

1. Through a 300 ohm dummy antenna, connect FM signal generator to 300 ohm FM antenna terminals.
2. Connect multiplex signal generator to external modulation terminals of FM SG.
3. Connect oscilloscope horizontal input to MPX SG pilot output and vertical input via probe to TP (No. 19) on the circuit board.
4. Set SX-650 dial indication to 98MHz and adjust FM SG for center scale indication on Tuning meter.

5. With FM SG unmodulated, adjust VR5 so that lissajous pattern on oscilloscope becomes stationary.
6. With MPX SG modulation 1kHz, L, R 67.5kHz deviation and Pilot 7.5kHz deviation, adjust T4 for minimum distortion.
7. Adjust VR4 for minimum signal leakage for R channel to L channel, and from L channel to R channel.

Lissajous

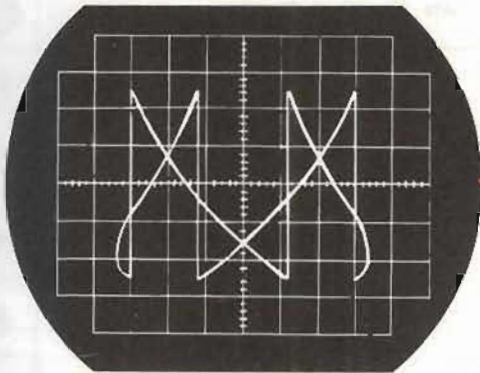

NOTE:



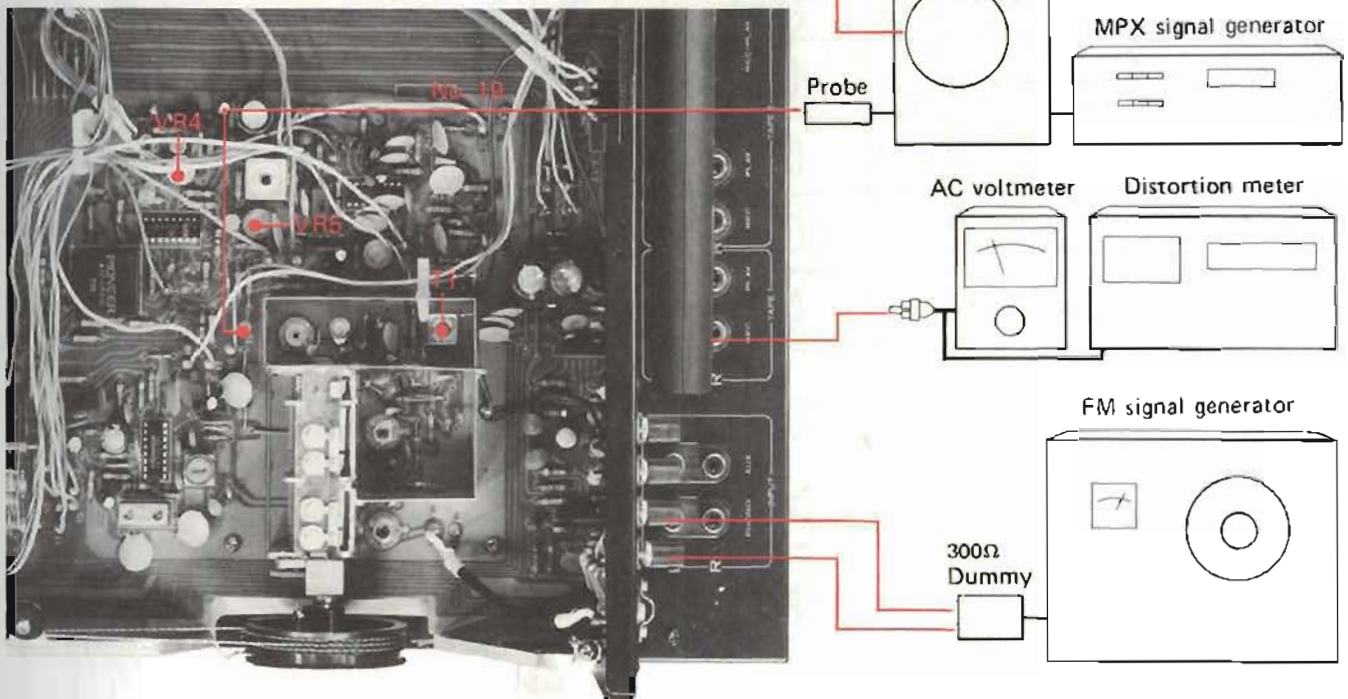











Signal at terminal No. 19 is 76kHz sawtooth wave and MPX SG pilot out is a 19kHz sine wave. These form Lissajous figure.











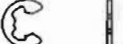

11. EXPLODED VIEWS

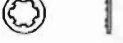
NOMENCLATURE OF SCREWS, WASHERS AND NUTS

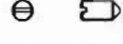
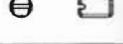
The following symbols stand for screws, washers and nuts as shown in exploded view.

Symbol	Description	Shape
RT	Brazier head tapping screw	
PT	Pan head tapping screw	
BT	Binding head tapping screw	
CT	Countersunk head tapping screw	
TT	Truss head tapping screw	
OCT	Oval countersunk head tapping screw	
PM	Pan head machine screw	
CM	Countersunk head machine screw	
OCM	Oval countersunk head machine screw	
TM	Truss head machine screw	
BM	Binding head machine screw	
PSA	Pan head screw with spring lock washer	
PSB	Pan head screw with spring lock washer and flat washer	
PSF	Pan head screw with flat washer	

Symbol	Description	Shape
EW	E type washer	
FW	Flat washer	
SW	Spring lock washer	
N	Nut	
WN	Washer faced nut	
ITW	Internal toothed lock washer	
OTW	Outernal toothed lock washer	
SC	Slotted set screw (Cone point)	
SF	Slotted set screw (Flat point)	
HS	Hexagon socket headless set screw	
OCW	Oval countersunk head wood screw	
CW	Countersunk head wood screw	
RW	Round head wood screw	

EXAMPLE

PM - 3x8
 length in mm (l)
 diameter in mm (d)
 Symbol

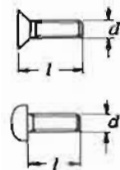

FW - $9\phi \times 1^r$
 thickness in mm (t)
 diameter in mm (d)
 Symbol

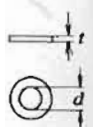

11.1 EXTERIOR

A

B

C

D

1

2

3

1

2

3

Part. 5
See page 43

Part. 1
See page 39

Part. 6
See page 44

Part. 4
See page 42

Part. 2
See page 40

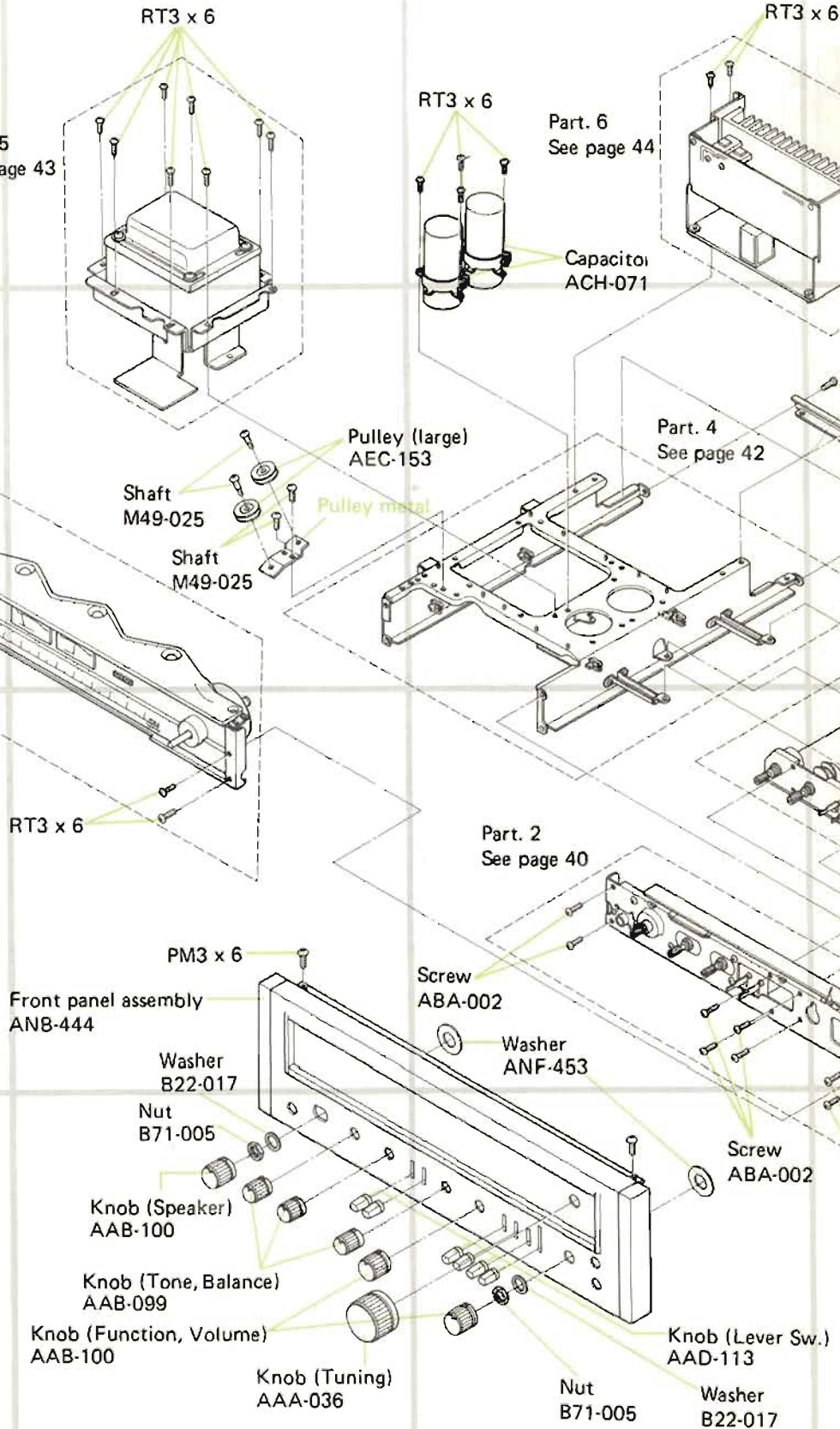

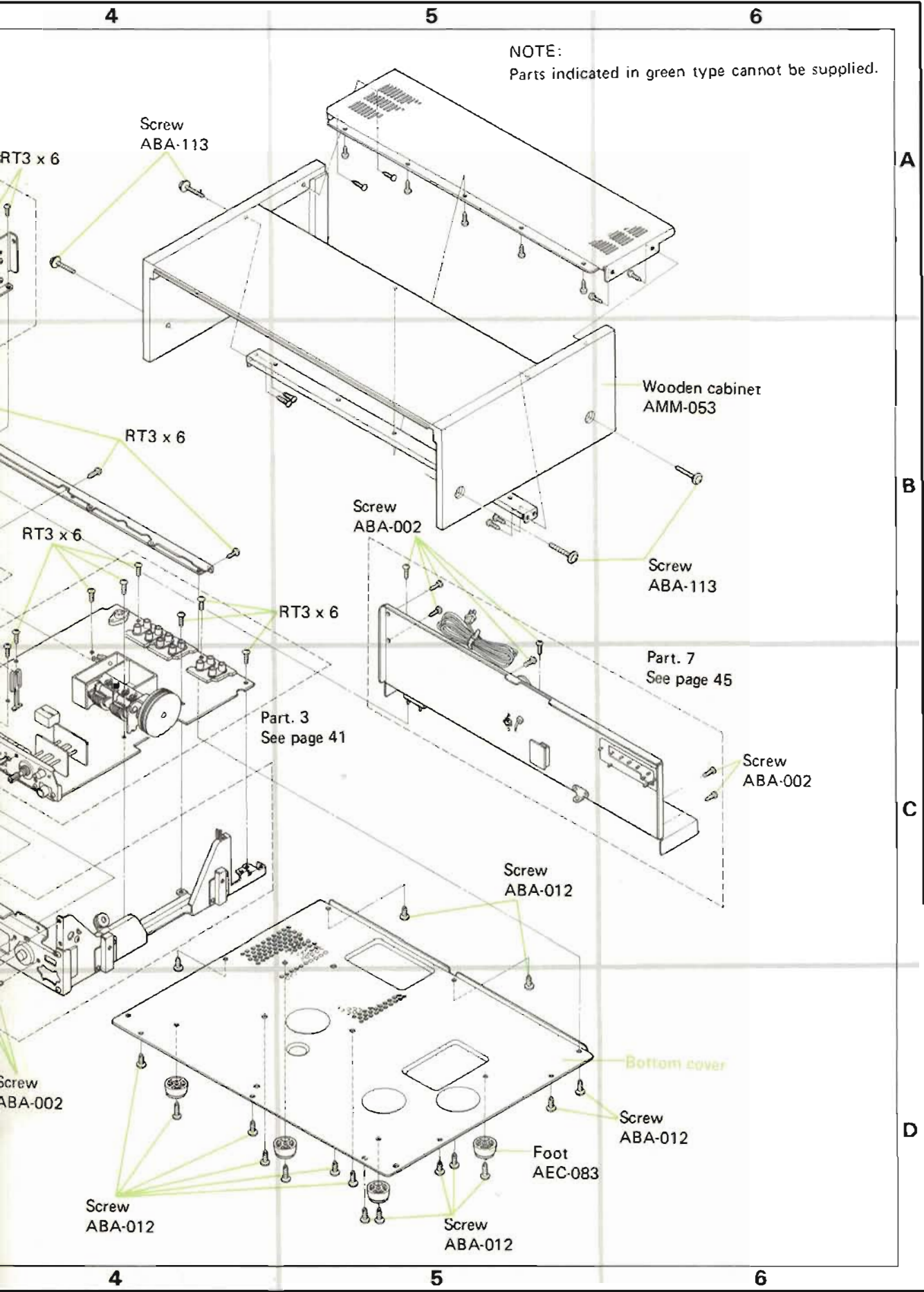

11.2 PART 1 DIAL SCALE

NOTE:
Parts indicated in green type cannot be supplied.

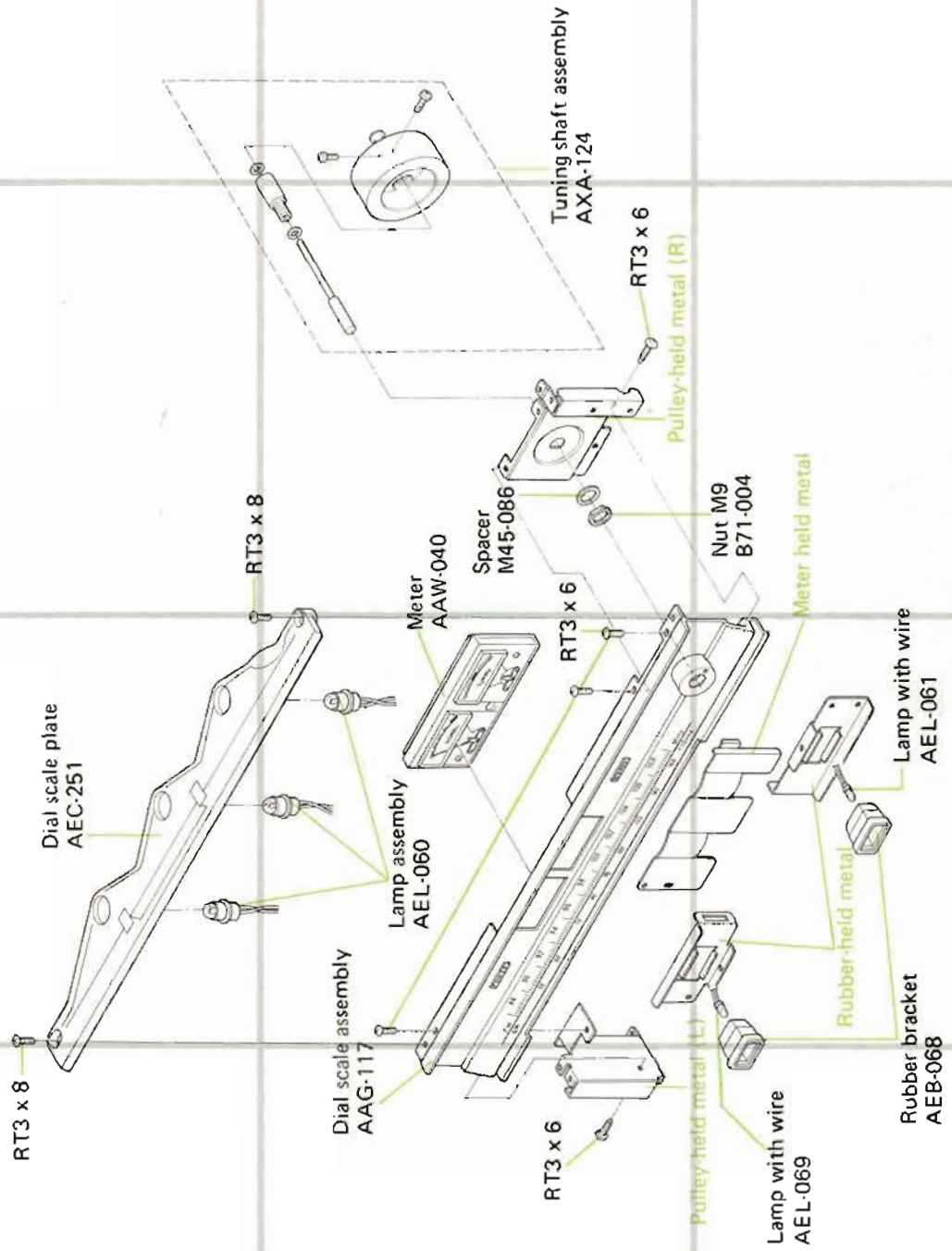

11.3 PART 2 DIAL FRAME

NOTE:
Parts indicated in green type cannot be supplied.

A

A

B

B

C

C

D

D

1

2

3

1

2

3

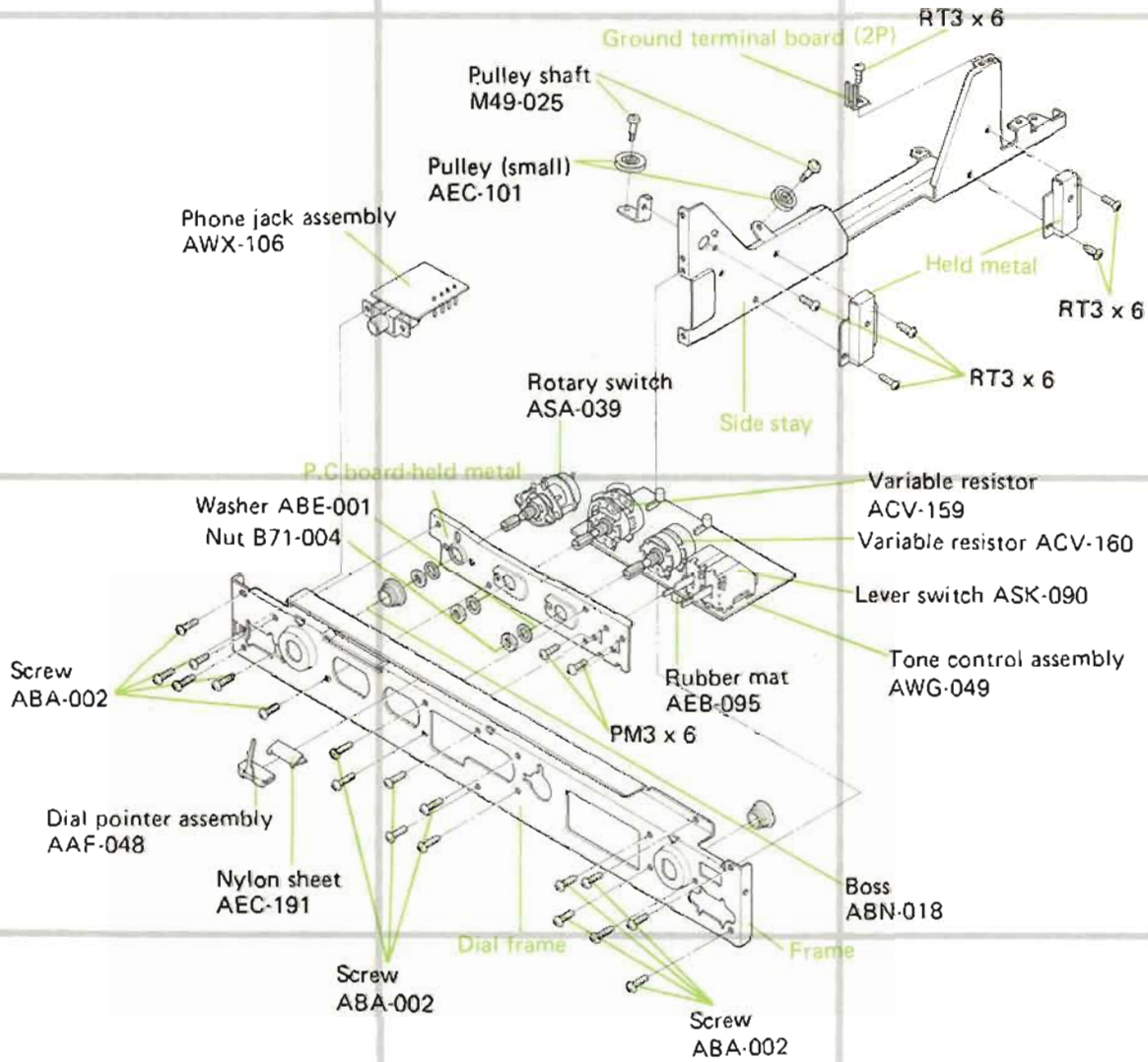

11.4 PART 3 TUNER AND AF ASSEMBLY

NOTE:
Parts indicated in green type cannot be supplied.

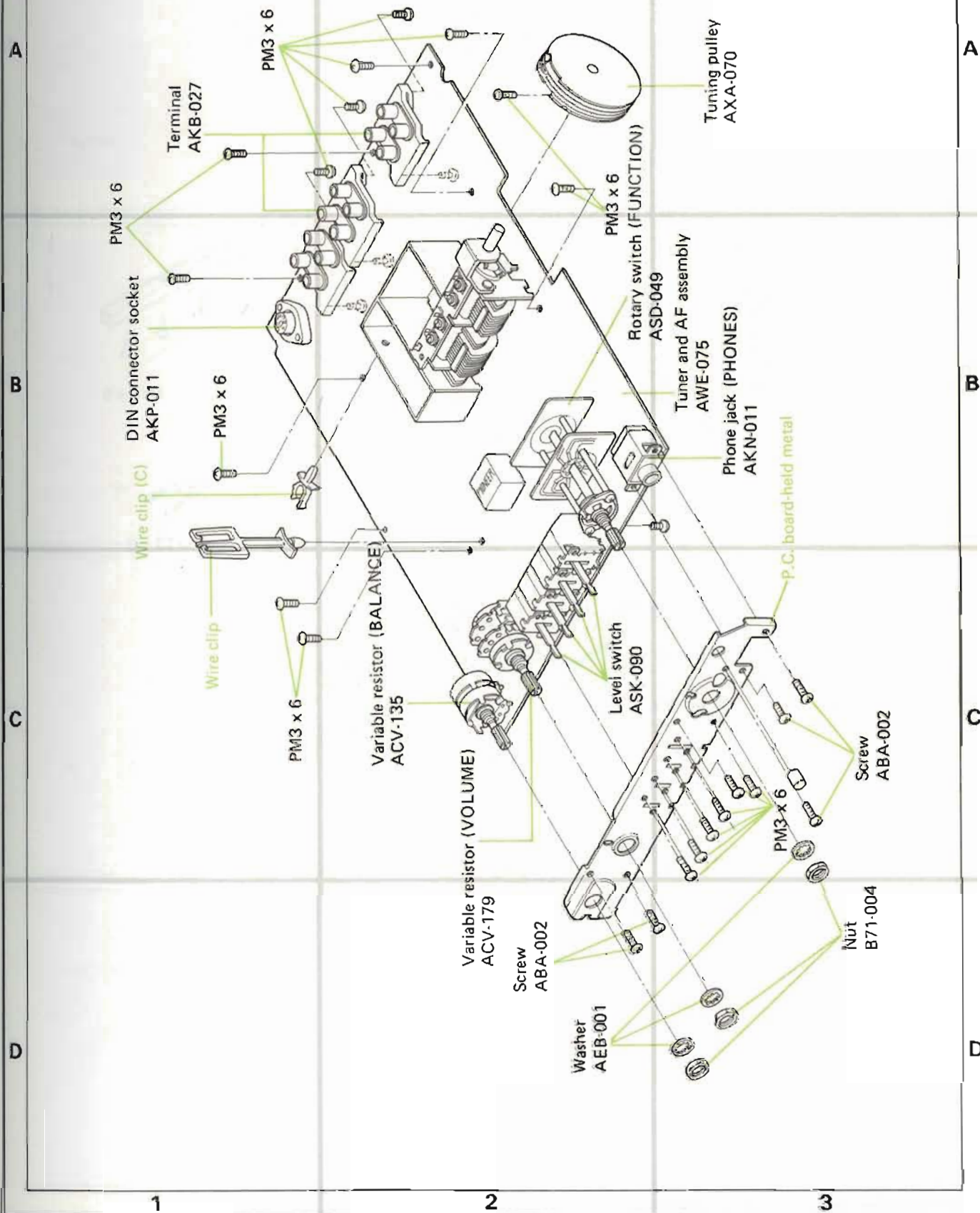

11.5 PART 4 POWER SUPPLY

NOTE:

Parts indicated in green type cannot be supplied.

A

B

C

D

1

2

3

1

2

3

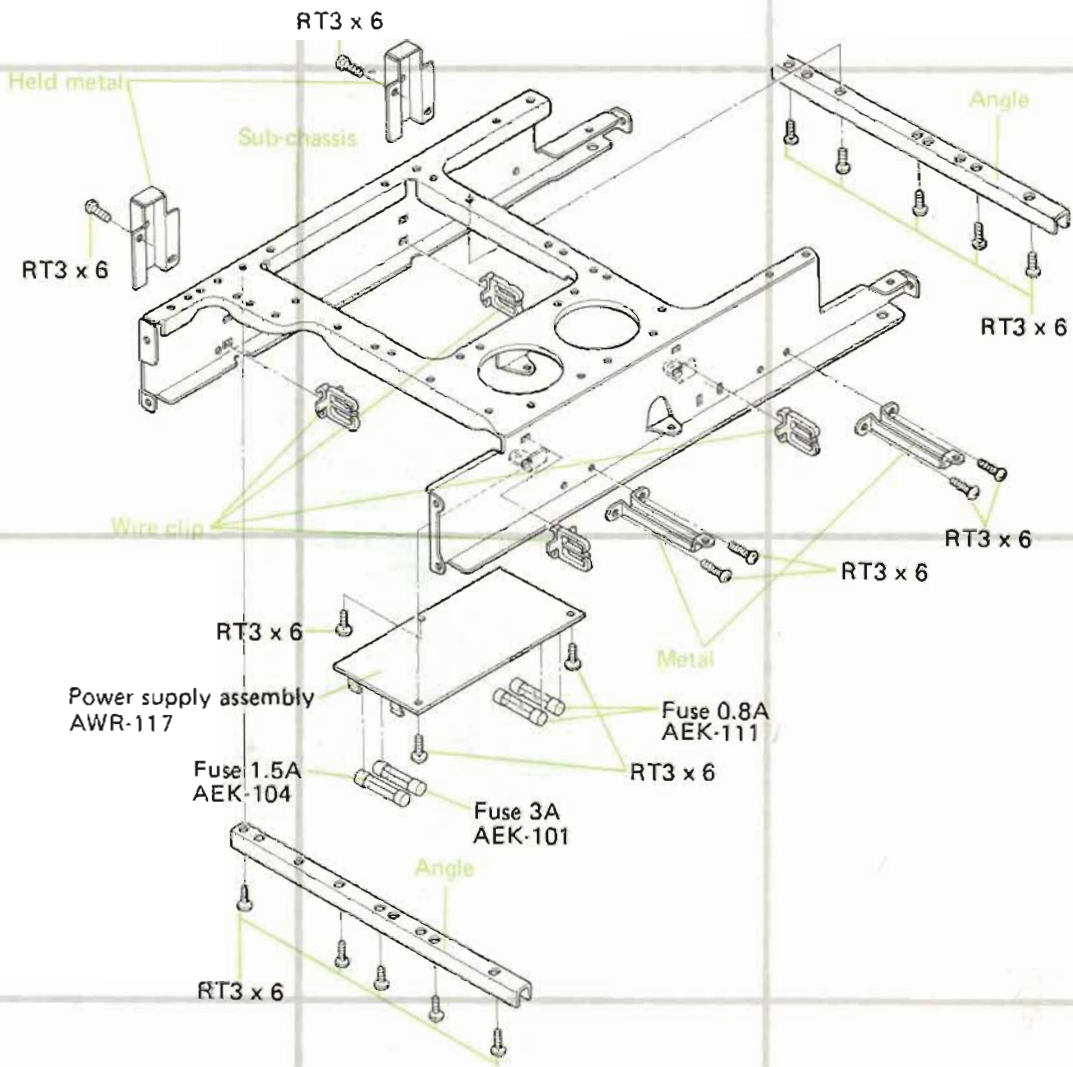

11.6 PART 5 POWER TRANSFORMER

Power transformer
ATT-315 (MODEL KC)
ATT-303 (MODEL KU)

NOTE:
Parts indicated in green type cannot be supplied.

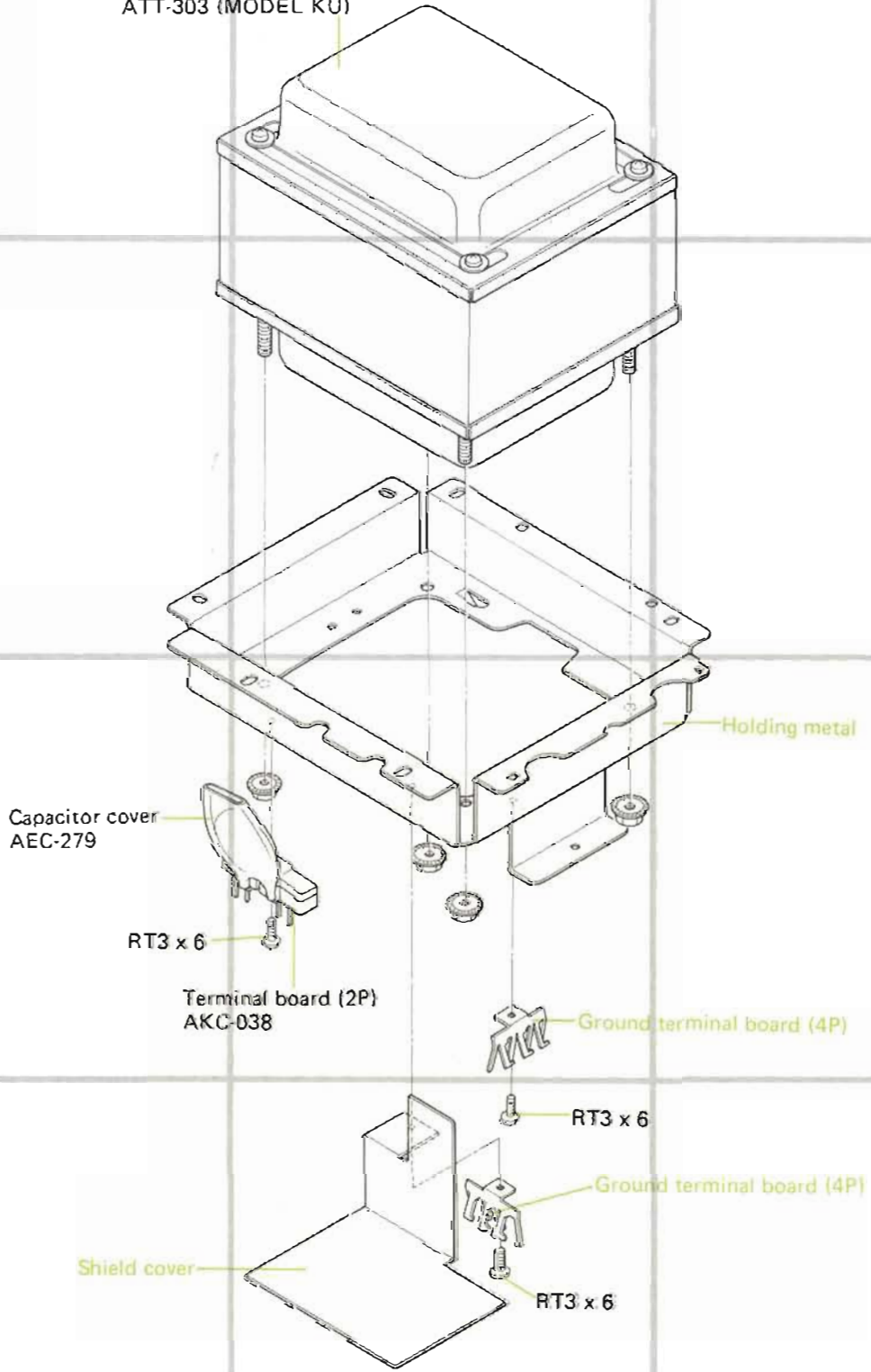

1

2

3

1

2

3

11.7 PART 6 POWER AMPLIFIER

NOTE:
Parts indicated in green type cannot be supplied.

A

A

B

B

C

C

D

D

RT3 x 6

Heat sink-hold metal (L)

Heat sink

IC
SP-40W

RT3 x 6

RT3 x 6

Heat sink-hold metal (R)

Power amplifier assembly 2
GWR-101

Cripe
AEC-036

Power amplifier assembly 1
GWH-101

RT3 x 6

1

2

3

11.8 PART 7 REAR PANEL

NOTE:
Parts indicated in green type cannot be supplied.

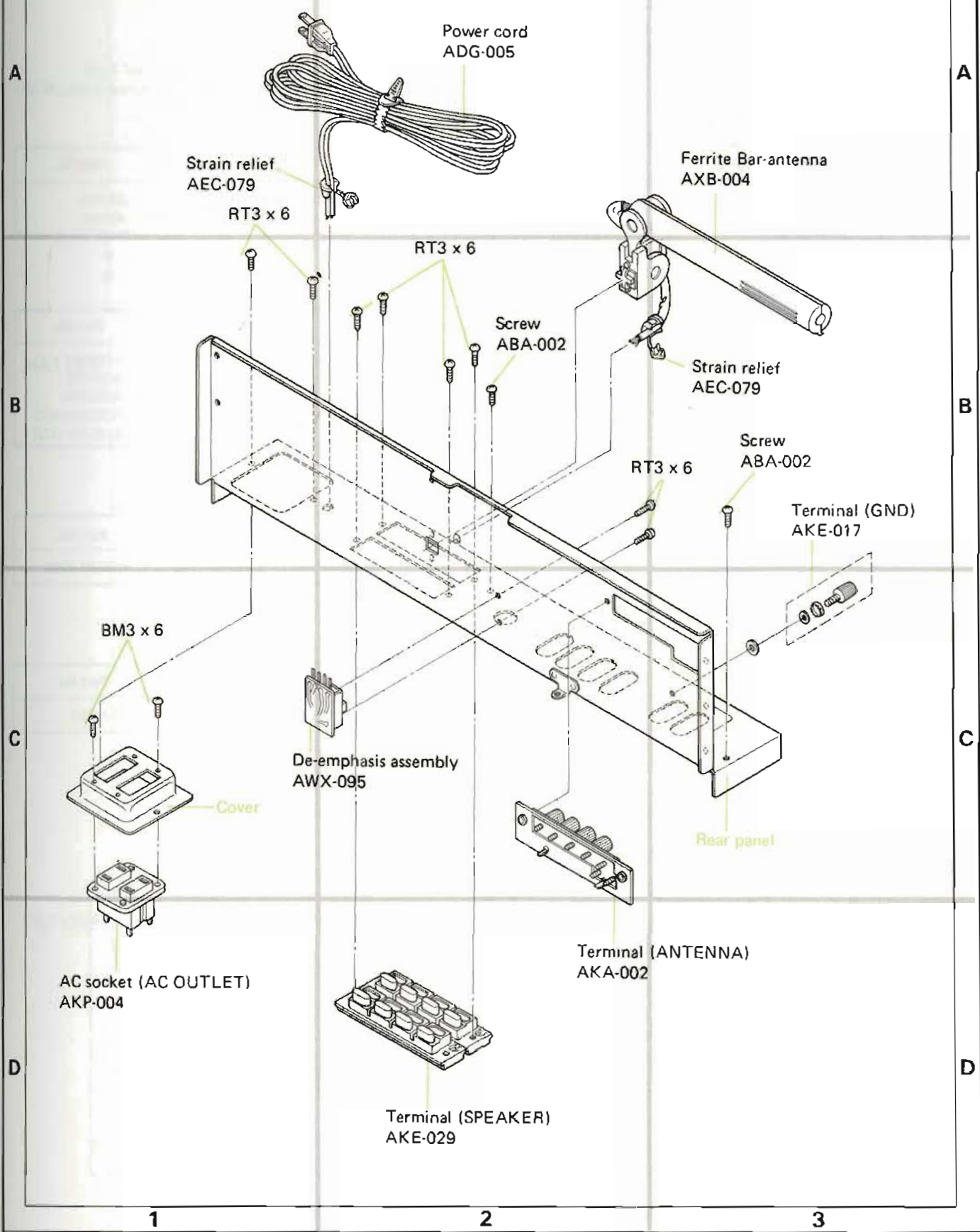

12. SCHEMATIC DIAGRAMS, P.C. BOARD PATTERNS AND PARTS LISTS

12.1 MISCELLANEOUS PARTS LIST

COILS AND TRANSFORMERS

Symbol	Description	Part No.
T1	Power transformer	ATT-315 (KC) ATT-303 (KU)
T2	Ferrite balun	T22-025
L1	Ferrite bar-antenna	AXB-004
L2	RF choke coil	T24-030

LAMPS

Symbol	Description	Part No.
PL1	Lamp assembly 8V 300mA	AEL-060
PL2	Lamp assembly 8V 300mA	AEL-060
PL3	Lamp assembly 8V 300mA	AEL-060
PL4	Lamp with leads 8V 50mA	AEL-069
PL5	Lamp with leads 8V 50mA	AEL-061

FUSES

Symbol	Description	Part No.
FU1	Fuse 1.5A	AEK-104
FU2	Fuse 0.8A	AEK-111
FU3	Fuse 0.8A	AEK-111
FU4	Fuse 3A	AEK-101

NOTE:

- Capacitors: in μF unless otherwise noted P:pF
- Resistors: in Ω , $\frac{1}{4}W$ unless otherwise noted k:k Ω , M:M Ω

SEMICONDUCTORS

Symbol	Description	Part No.
Q1	Transistor	SP-40W
Q2	Transistor	SP-40W

CAPACITORS

Symbol	Description	Part No.
C1	Electrolytic 8000 50V	ACH-071
C2	Electrolytic 8000 50V	ACH-071
C3	Ceramic 0.01	ACG-003
C4	Ceramic 0.01	ACG-003 (KC) ACG-001 (KU)

RESISTOR

Symbol	Description	Part No.
R1	Carbon film 2.2M $\frac{1}{4}W$	RD $\frac{1}{2}$ PS 225J

SWITCH

Symbol	Description	Part No.
S1	Selector switch (POWER)	ASA-039

Circuit Diagrams of ICs

HA1138 (AM IC)

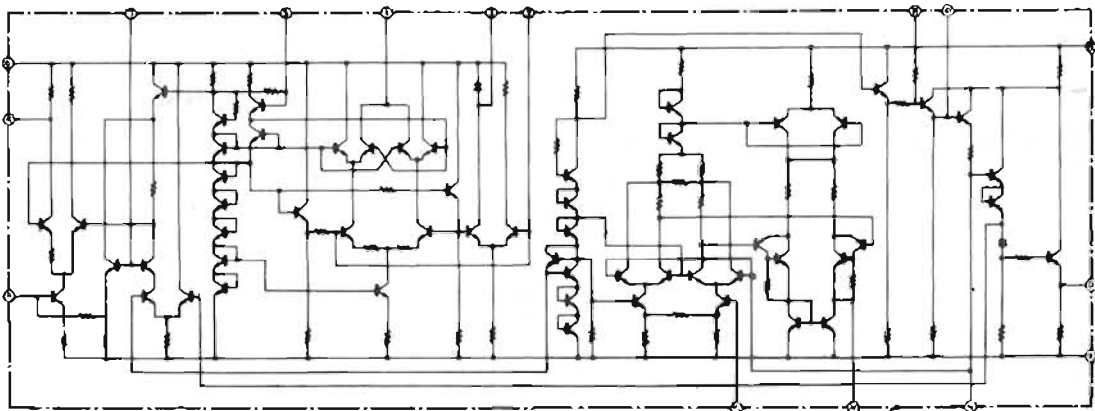

HA1137 (FM IF IC)

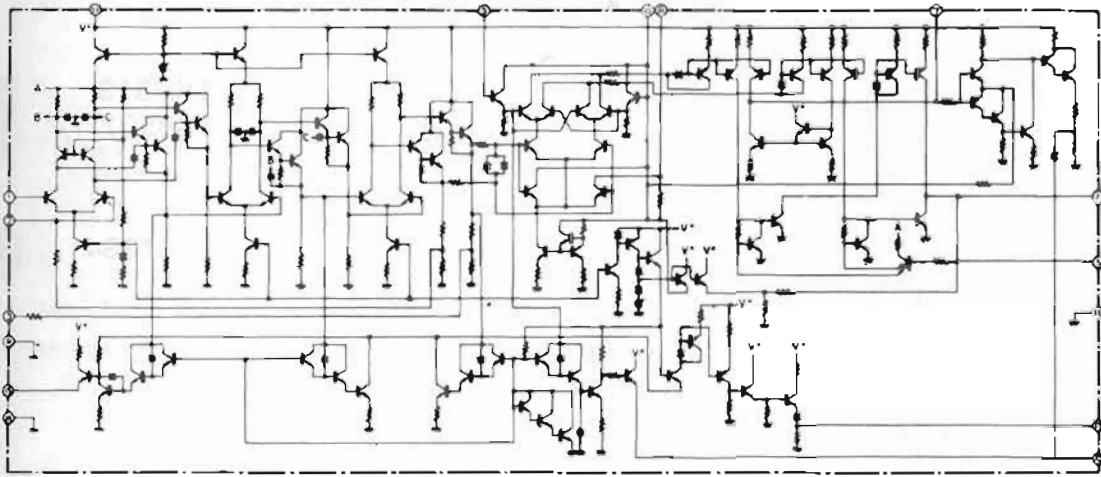

HA1196

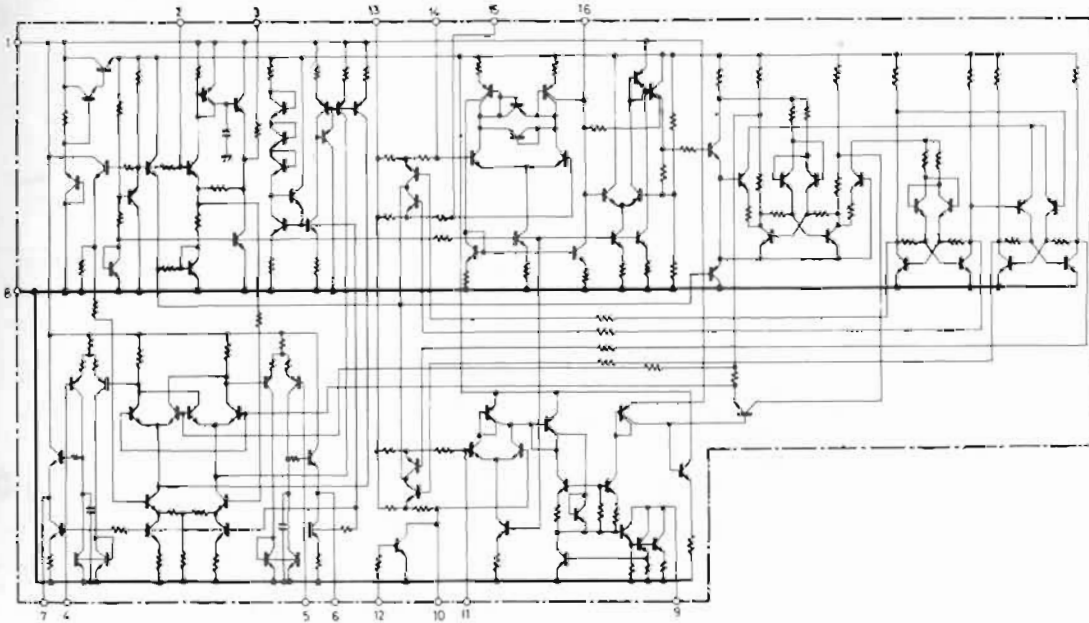

SP-40W

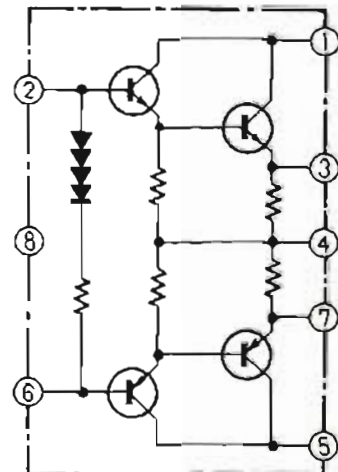

TA7136P1

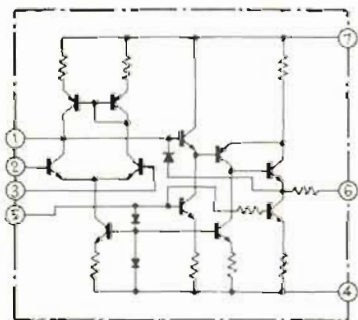

External Appearance of Transistors and ICs

2SK55

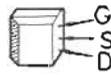

2SA798

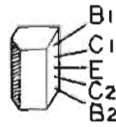

2SD313
2SB507

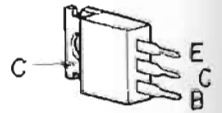

2SC535
2SC461
2SC1344

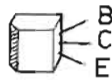

2SC1438
2SC1647
2SA823
2SC1649
2SC945A

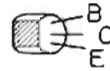

2SC1384



HA1137
HA1138
HA1196

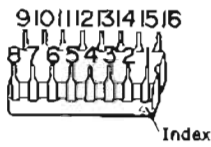

TA7136P

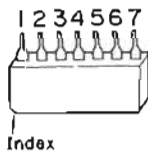

12.2 SCHEMATIC DIAGRAM

NOTE: The IC type of phono equalizer is identified by TUNER and AF Assembly AWE-075 while the discrete component type has the number AWE-075-A.

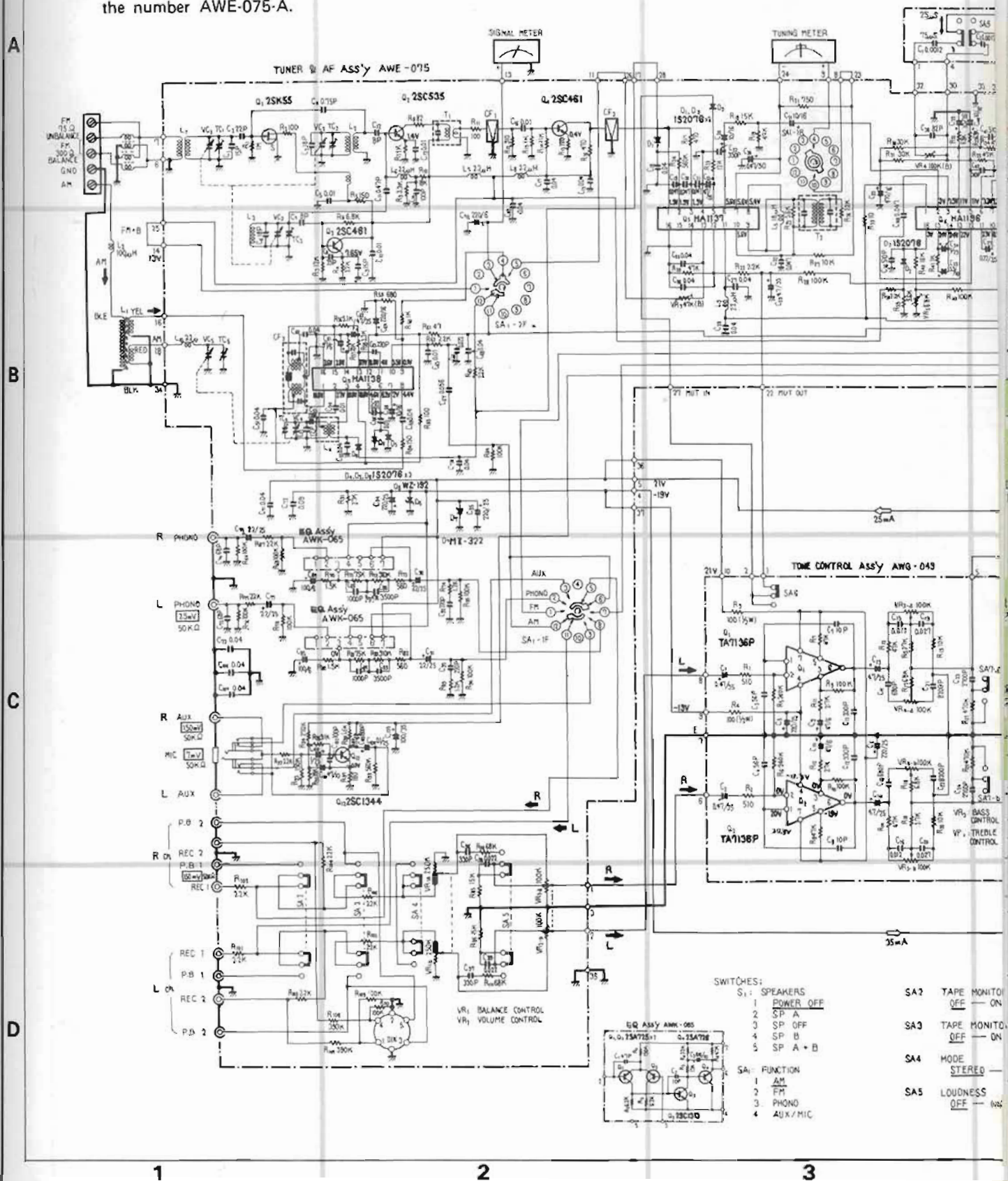

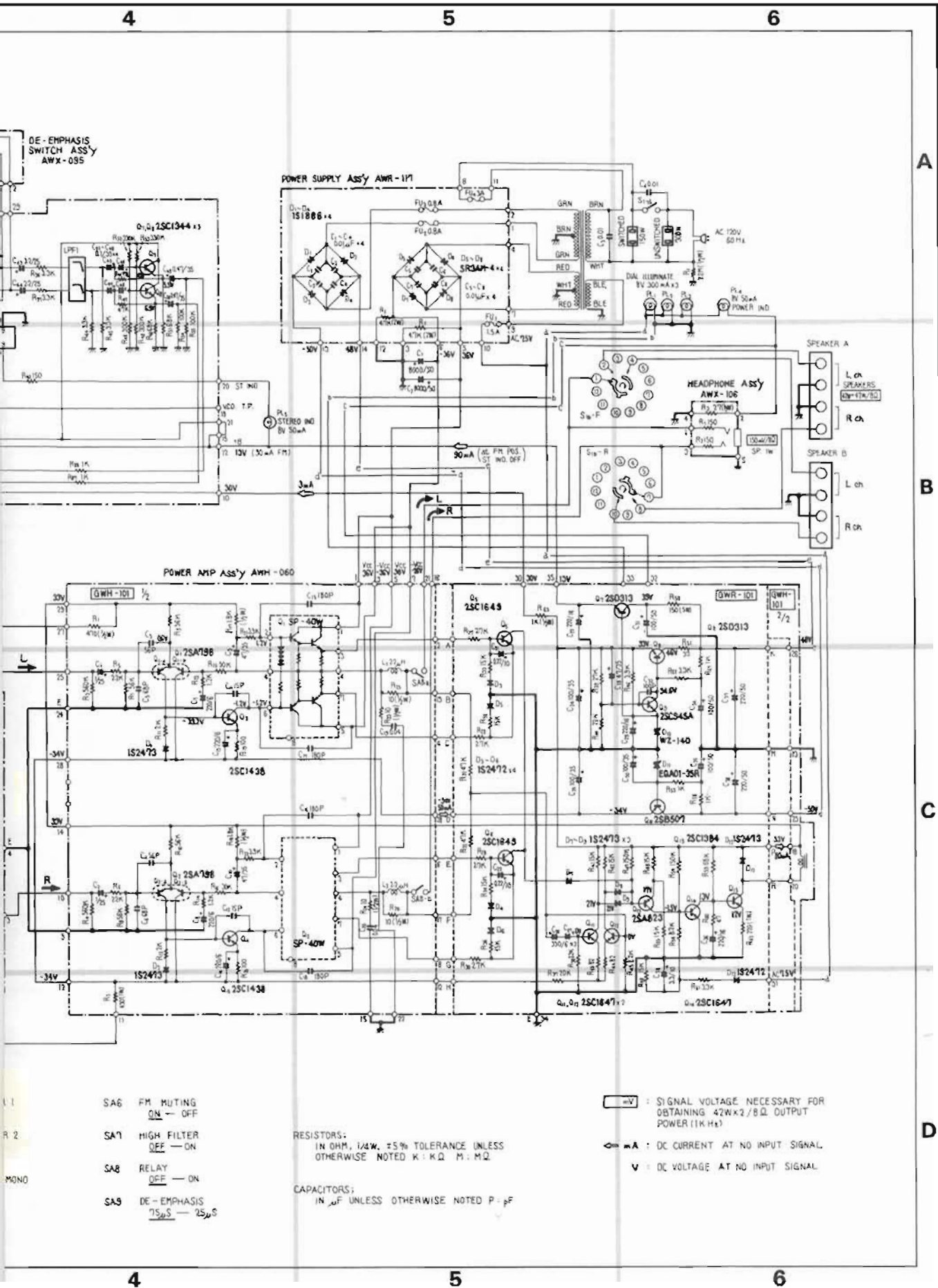

12.3 TUNER AND AF ASSEMBLY (AWE-075-A)

NOTE: IC type may also be used in the equalizer amplifier in place of the Discrete components shown on this diagram.

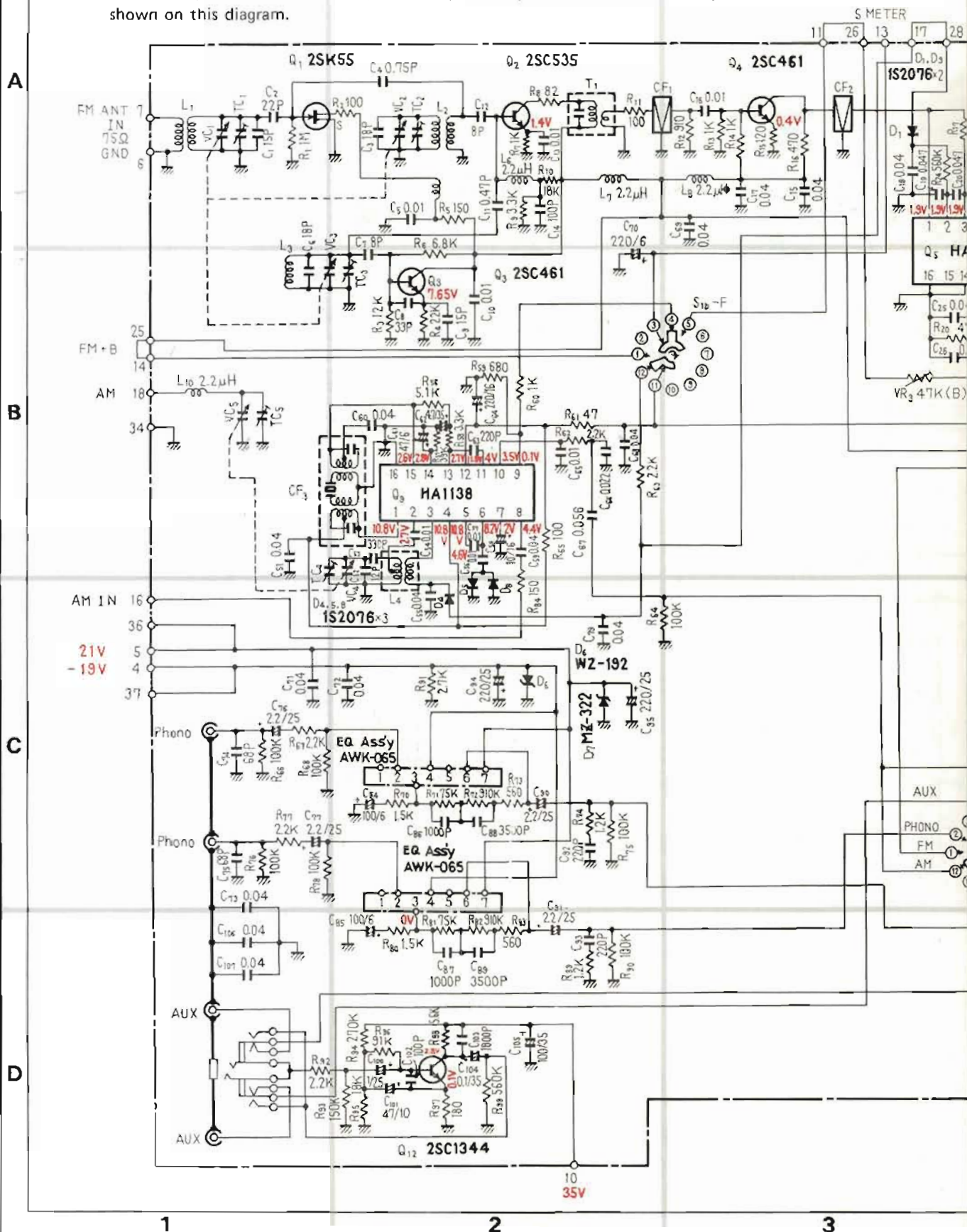

4

5

6

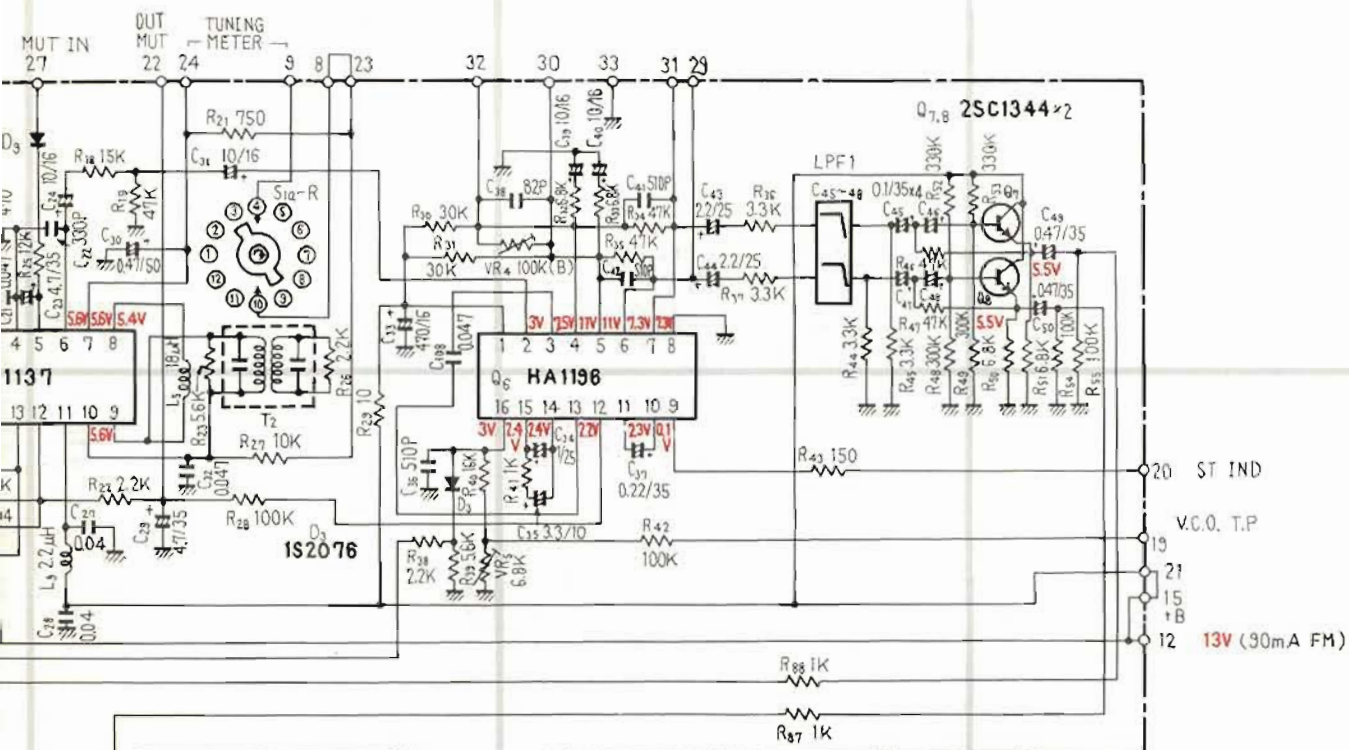

A

B

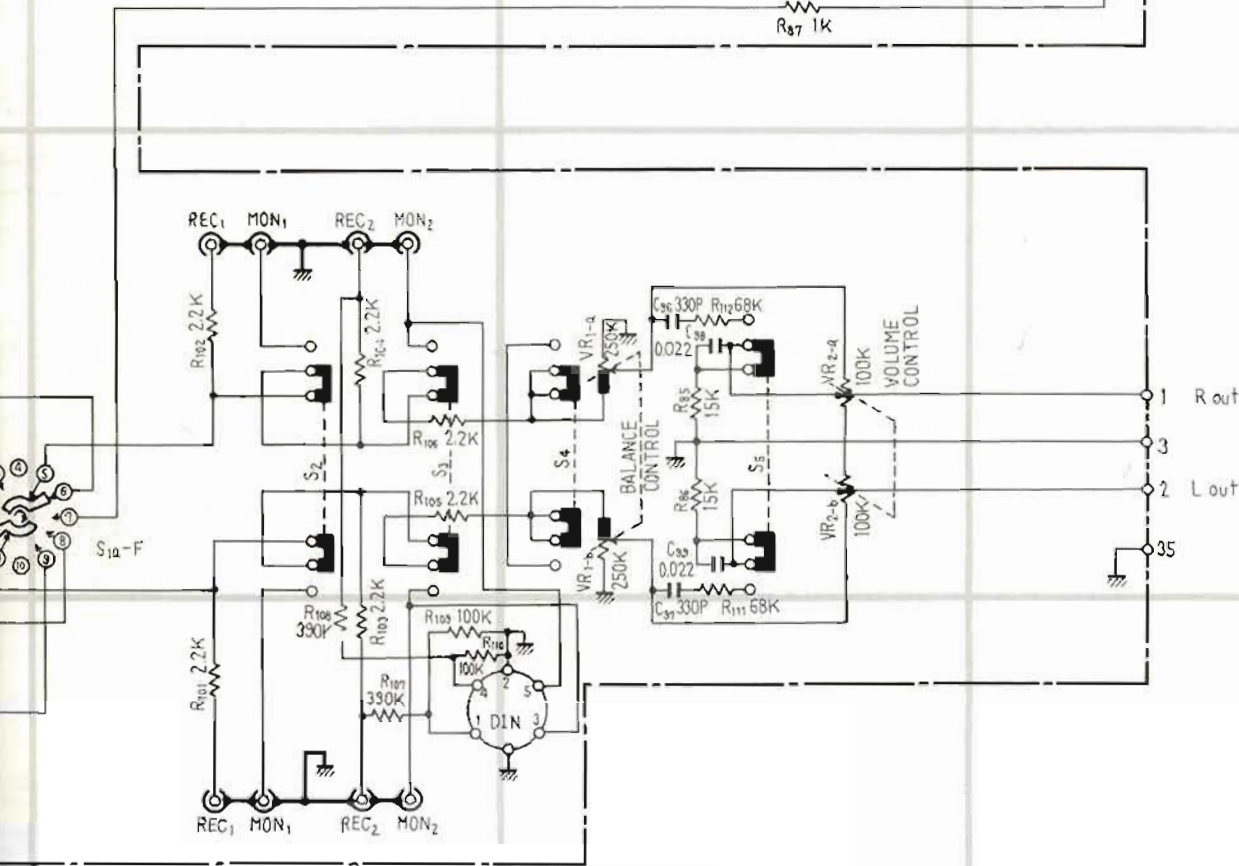

C

D

4

5

6

AWG-049, No. 10
 AWG-049, No. 9

37 36

25 26

22

GWH-101, No. 11
 GWH-101, No. 27

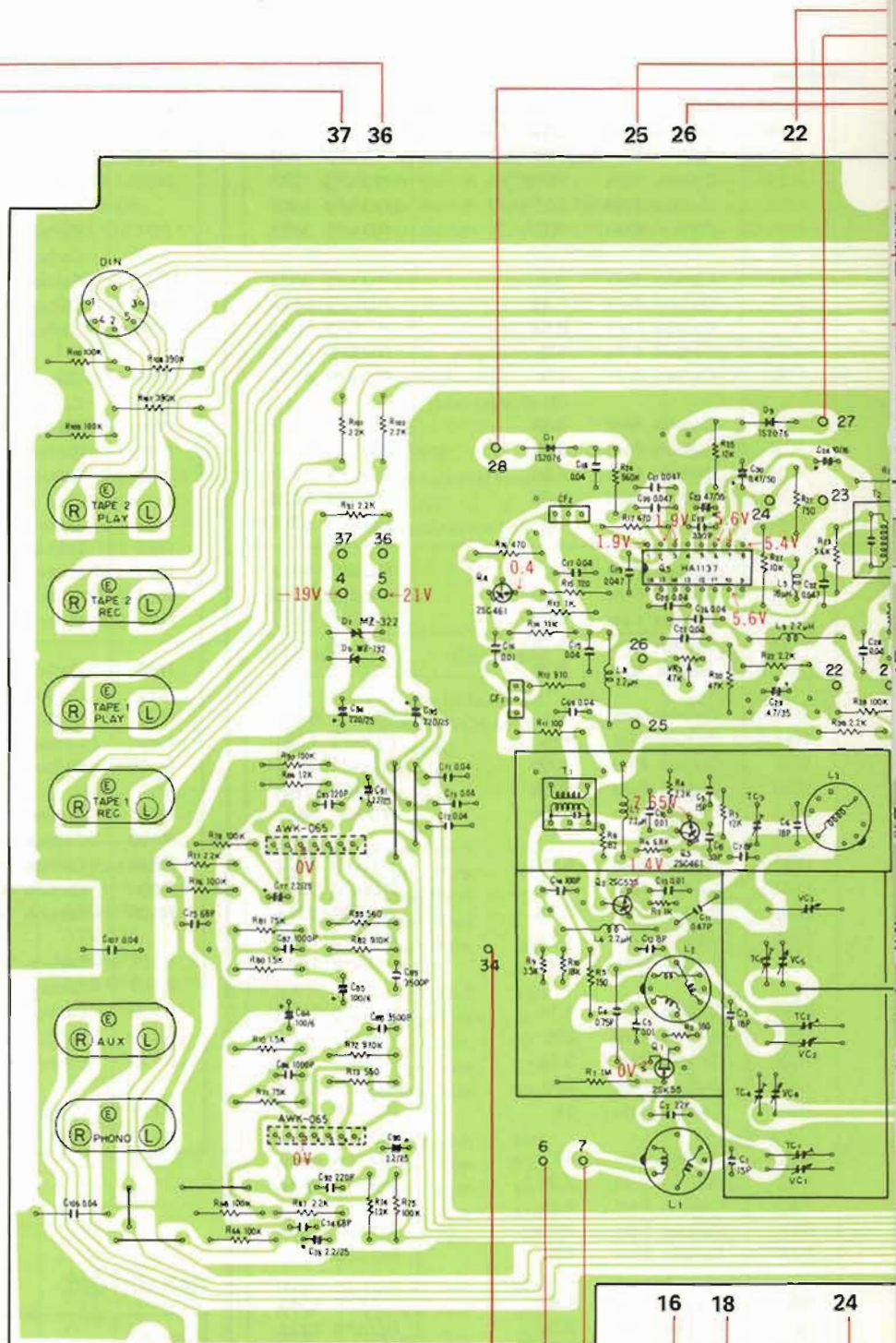

FM 75Ω
 UNBALANCE

RM 300Ω
 BALANCE

GND

16 18 24

YEL
 RED
 BLK

AM

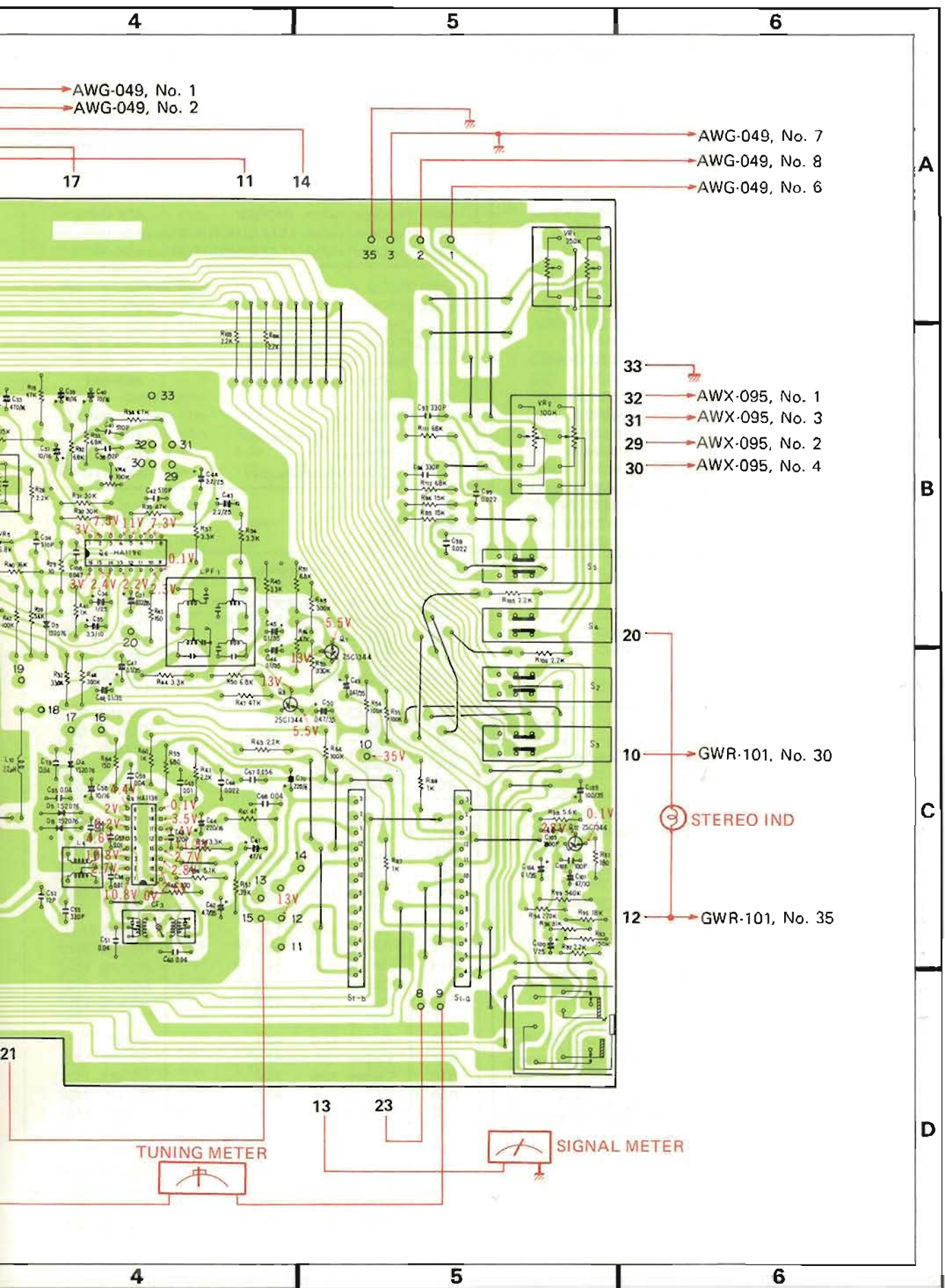

→ AWG-049, No. 1
 → AWG-049, No. 2

17 11 14

→ AWG-049, No. 7
 → AWG-049, No. 8
 → AWG-049, No. 6

A

33 →
 32 → AWX-095, No. 1
 31 → AWX-095, No. 3
 29 → AWX-095, No. 2
 30 → AWX-095, No. 4

B

20 →
 10 → GWR-101, No. 30

C

⊕ STEREO IND

12 → GWR-101, No. 35

D

TUNING METER

SIGNAL METER

4

5

6

Parts List of Tuner and AF Assembly (AWE-075-A)

SEMICONDUCTORS

Symbol	Description	Part No.
Q1	Transistor	2SK55-D
Q2	Transistor	2SC535-A
Q3	Transistor	2SC461-B
Q4	Transistor	2SC461-B
Q5	IC	HA1137
Q6	IC	HA1196
Q7	Transistor	2SC1344-D
Q8	Transistor	2SC1344-D
Q9	IC	HA1138
Q12	Transistor	2SC1344-D
D1	Diode	1S2076
D3	Diode	1S2076
D4	Diode	1S2076
D5	Diode	1S2076
D6	Zener diode	WZ-192
D7	Zener diode	MZ322-A
D8	Diode	1S2076
D9	Diode	1S2076

TRANSFORMERS AND COILS

Symbol	Description	Part No.
L1	FM antenna coil	ATC-023
L2	FM RF coil	ATC-024
L3	FM oscillator coil	ATC-025
L4	AM oscillator coil	ATB-013
L5	Micro inductor	ATH-007
L6	RF choke coil	T24-028
L7	RF choke coil	T24-028
L8	RF choke coil	T24-028
L9	RF choke coil	T24-028
L10	RF choke coil	T24-028
T1	FM matching transformer	ATE-008
T2	FM IF transformer	T73-035
CF1	FM ceramic filter	ATF-013
CF2	FM ceramic filter	ATF-013
CF3	AM ceramic filter	ATF-027
LPF1	Low pass filter	ATF-033

SWITCHES

Symbol	Description	Part No.
S1	Rotary switch (FUNCTION)	ASD-049
S2	Lever switch (LOUDNESS)	ASK-090
S3	Lever switch (MODE)	ASK-090
S4	Lever switch (TAPE MONITOR)	ASK-090
S5	Lever switch (TAPE MONITOR)	ASK-090

OTHERS

Symbol	Description	Part No.
J1	Phone jack (PHONES)	AKN-011
	Nut (M9)	B71-004
	Inside-toothed washer	ABE-001
	Terminal	AKB-027
	DIN connector socket	AKP-011

RESISTORS

Symbol	Description	Part No.
VR1	Variable (BALANCE) 250k	ACV-135
VR2	Variable (VOLUME) 100k	ACV-179
VR3	Semi-fixed	C92-048
VR4	Semi-fixed	C92-047
VR5	Semi-fixed	ACP-023
R1	Carbon film 1M	RD%PS 105J
R2	Carbon film 100	RD%VS 101J
R3	Carbon film 12k	RD%VS 123J
R4	Carbon film 2.2k	RD%VS 222J
R5	Carbon film 150	RD%PS 151J
R6	Carbon film 6.8k	RD%VS 682J
R7	Carbon film 1k	RD%VS 102J
R8	Carbon film 82	RD%VS 820J
R9	Carbon film 3.3k	RD%VS 332J
R10	Carbon film 18k	RD%VS 183J
R11	Carbon film 100	RD%PS 101J
R12	Carbon film 910	RD%PM 911J
R13	Carbon film 1k	RD%PS 102J
R14	Carbon film 11k	RD%PS 113J
R15	Carbon film 120	RD%PS 121J
R16	Carbon film 470	RD%PS 471J
R17	Carbon film 470	RD%PS 471J
R18	Carbon film 15k	RD%PS 153J
R19	Carbon film 47k	RD%PS 473J
R20	Carbon film 47k	RD%PS 473J
R21	Carbon film 750	RD%PS 751J
R22	Carbon film 2.2k	RD%PS 222J
R23	Carbon film 5.6k	RD%PS 562J
R24	Carbon film 560k	RD%PS 564J
R25	Carbon film 12k	RD%PS 123J

Symbol	Description	Part No.
R26	Carbon film 2.2k	RD%PS 222J
R27	Carbon film 10k	RD%PS 103J
R28	Carbon film 100k	RD%PS 104J
R29	Carbon film 10	RD%PS 100J
R30	Carbon film 30k	RD%PS 303J
R31	Carbon film 30k	RD%PS 303J
R32	Carbon film 6.8k	RD%PS 682J
R33	Carbon film 6.8k	RD%PS 682J
R34	Carbon film 47k	RD%PS 473J
R35	Carbon film 47k	RD%PS 473J
R36	Carbon film 3.3k	RD%PS 332J
R37	Carbon film 3.3k	RD%PS 332J
R38	Carbon film 2.2k	RD%PS 222J
R39	Carbon film 5.6k	RD%PS 562J
R40	Metal film 16k	RN%PT 1602F
R41	Carbon film 1k	RD%PS 102J
R42	Carbon film 100k	RD%PS 104J
R43	Carbon film 150	RD%PS 151J
R44	Carbon film 3.3k	RD%PS 332J
R45	Carbon film 3.3k	RD%PS 332J
R46	Carbon film 47k	RD%PS 473J
R47	Carbon film 47k	RD%PS 473J
R48	Carbon film 300k	RD%PS 304J
R49	Carbon film 300k	RD%PS 304J
R50	Carbon film 6.8k	RD%PS 682J
R51	Carbon film 6.8k	RD%PS 682J
R52	Carbon film 330k	RD%PS 334J
R53	Carbon film 330k	RD%PS 334J
R54	Carbon film 100k	RD%PS 104J
R55	Carbon film 100k	RD%PS 104J
R56	Carbon film 5.1k	RD%PS 512J
R57	Carbon film 39k	RD%PS 393J
R58	Carbon film 3.3k	RD%PS 332J
R59	Carbon film 680	RD%PS 681J
R60	Carbon film 1k	RD%PS 102J
R61	Carbon film 47	RD%PS 470J
R62	Carbon film 2.2k	RD%PS 222J
R63	Carbon film 2.2k	RD%PS 222J
R64	Carbon film 100k	RD%PS 104J
R65	Carbon film 100	RD%PS 101J
R66	Carbon film 100k	RD%PS 104J
R67	Carbon film 2.2k	RD%PS 222J
R68	Carbon film 100k	RD%PS 104J
R71	Carbon film 75k	RD%PS 753J
R72	Carbon film 910k	RD%PS 914J
R73	Carbon film 560	RD%PS 561J
R74	Carbon film 1.2k	RD%PS 122J
R75	Carbon film 100k	RD%PS 104J
R76	Carbon film 100k	RD%PS 104J

Symbol	Description	Part No.
R77	Carbon film 2.2k	RD%PS 222J
R78	Carbon film 100k	RD%PS 104J
R80	Carbon film 1.5k	RD%PS 152J
R81	Carbon film 75k	RD%PS 753J
R82	Carbon film 910k	RD%PS 914J
R83	Carbon film 560	RD%PS 561J
R84	Carbon film 150	RD%PS 151J
R85	Carbon film 15k	RD%PS 153J
R86	Carbon film 15k	RD%PS 153J
R87	Carbon film 1k	RD%PS 102J
R88	Carbon film 1k	RD%PS 102J
R89	Carbon film 1.2k	RD%PS 122J
R90	Carbon film 100k	RD%PS 104J
R91	Carbon film 2.7k	RD%PS 272J
R92	Carbon film 2.2k	RD%PS 222J
R93	Carbon film 150k	RD%PS 154J
R94	Carbon film 270k	RD%PS 274J
R95	Carbon film 18k	RD%PS 183J
R96	Carbon film 91k	RD%PS 913J
R97	Carbon film 180	RD%PS 181J
R98	Carbon film 5.6k	RD%PS 562J
R99	Carbon film 560k	RD%PS 564J
R100	Carbon film 1k	RD%PS 102J
R101	Carbon film 2.2k	RD%PS 222J
R102	Carbon film 2.2k	RD%PS 222J
R103	Carbon film 2.2k	RD%PS 222J
R104	Carbon film 2.2k	RD%PS 222J
R105	Carbon film 2.2k	RD%PS 222J
R106	Carbon film 2.2k	RD%PS 222J
R107	Carbon film 390k	RD%PS 394J
R108	Carbon film 390k	RD%PS 394J
R109	Carbon film 100k	RD%PS 104J
R110	Carbon film 100k	RD%PS 104J
R111	Carbon film 68k	RD%PS 683J
R112	Carbon film 68k	RD%PS 683J

CAPACITORS

Symbol	Description	Part No.
	Variable capacitor	ACK-012
	Ceramic trimmer	ACM-006
C1	Ceramic 15p 50V	CCDTH 150K 50
C2	Ceramic 22p 50V	CCDSL 220K 50
C3	Ceramic 18p 50V	CCDTH 180K 50
C4	Ceramic 0.75p 500V	CG6 R75K 500
C5	Ceramic 0.01 50V	CKDYF 103Z 50

Symbol	Description			Part No.
C6	Ceramic	18p	50V	CCDSH 180K 50
C7	Ceramic	8p	50V	CCDCH 080F 50
C8	Ceramic	33p	50V	CCDCH 330K 50
C9	Ceramic	15p	50V	CCDCH 150K 50
C10	Ceramic	0.01	50V	CKDYB 103K 50
C11	Ceramic	0.47p	500V	CGB R47K 500
C12	Ceramic	8p	50V	CCDSL 080F 50
C13	Ceramic	0.01	50V	CKDYF 103Z 50
C14	Ceramic	100p	50V	CCDSL 101K 50
C15	Ceramic	0.04	50V	CKDYF 403Z 50
C16	Ceramic	0.01	50V	CKDYF 103Z 50
C17	Ceramic	0.04	50V	CKDYF 403Z 50
C18	Ceramic	0.04	50V	CKDYF 403Z 50
C19	Ceramic	0.047	50V	CKDBC 473Z 50
C20	Ceramic	0.047	50V	CKDBC 473Z 50
C21	Ceramic	0.047	50V	CKDBC 473Z 50
C22	Ceramic	330p	50V	CKDYB 331K 50
C23	Electrolytic	4.7	35V	CEA 4R7P 35
C24	Electrolytic	10	16V	CSZA 100M 16
C25	Ceramic	0.04	50V	CKDYF 403Z 50
C26	Ceramic	0.04	50V	CKDYF 403Z 50
C27	Ceramic	0.04	50V	CKDYF 403Z 50
C28	Ceramic	0.04	50V	CKDYF 403Z 50
C29	Electrolytic	4.7	35V	CEA 4R7P 35
C30	Electrolytic	0.47	50V	CEA R47P 50
C31	Electrolytic	10	16V	CSZA 100M 16
C32	Ceramic	0.047	50V	CKDBC 473Z 50
C33	Electrolytic	470	16V	CEA 471P 16
C34	Electrolytic	1	25V	CSZA 010M 25
C35	Electrolytic	3.3	10V	CSZA 3R3M 10
C36	Polystyrene film	510p	50V	CQSH 511J 50
C37	Electrolytic	0.22	25V	CSZA R22M 25
C38	Ceramic	82p	50V	CCDSL 820K 50
C39	Electrolytic	10	16V	CEA 100P 16
C40	Electrolytic	10	16V	CEA 100P 16
C41	Polystyrene film	510p	50V	CQSA 511J 50
C42	Polystyrene film	510p	50V	CQSA 511J 50
C43	Electrolytic	2.2	25V	CSZA 2R2M 25
C44	Electrolytic	2.2	25V	CSZA 2R2M 25
C45	Electrolytic	0.1	25V	CSZA 0R1M 25
C46	Electrolytic	0.1	25V	CSZA 0R1M 25
C47	Electrolytic	0.1	25V	CSZA 0R1M 25
C48	Electrolytic	0.1	25V	CSZA 0R1M 25
C49	Electrolytic	0.47	25V	CSZA R47M 25
C50	Electrolytic	0.47	25V	CSZA R47M 25
C51	Ceramic	0.04	50V	CKDYF 403Z 50
C52	Ceramic	12p	50V	CCDXL 120K 50
C53	Polystyrene film	330p	50V	CQSA 331J 50
C54	Ceramic	0.01	50V	CKDYF 103Z 50
C55	Ceramic	0.04	50V	CKDYF 403Z 50

Symbol	Description			Part No.
C56	Ceramic	0.01	50V	CKDYF 103Z 50
C57	Ceramic	0.01	50V	CKDYF 103Z 50
C58	Electrolytic	10	16V	CEA 100P 16
C59	Ceramic	0.04	50V	CKDYF 403Z 50
C60	Ceramic	0.04	50V	CKDYF 403Z 50
C61	Electrolytic	47	6V	CEA 470P 6
C62	Electrolytic	4.7	35V	CEA 4R7P 35
C63	Ceramic	220p	50V	CCDSL 221K 50
C64	Electrolytic	220	16V	CEA 221P 16
C65	Ceramic	0.01	50V	CKDYF 103Z 50
C66	Ceramic	0.022	50V	CKDYF 223Z 50
C67	Mylar	0.056	50V	CQMA 563K 50
C68	Ceramic	0.04	50V	CKDYF 403Z 50
C69	Ceramic	0.04	50V	CKDYF 403Z 50
C70	Electrolytic	220	6V	CEA 221P 6
C71	Ceramic	0.04	50V	CKDYF 403Z 50
C72	Ceramic	0.04	50V	CKDYF 403Z 50
C73	Ceramic	0.04	50V	CKDYF 403Z 50
C74	Ceramic	68p	50V	CCDSL 680K 50
C75	Ceramic	68p	50V	CCDSL 680K 50
C76	Electrolytic	2.2	25V	CSZA 2R2M 25
C77	Electrolytic	2.2	25V	CSZA 2R2M 25
C84	Electrolytic	100	6V	CEA 101P 6
C85	Electrolytic	100	6V	CEA 101P 6
C86	Polystyrene film	1000p	50V	CQSA 102G 50
C87	Polystyrene film	1000p	50V	CQSA 102G 50
C88	Polystyrene film	3500p	50V	CQSA 352G 50
C89	Polystyrene film	3500p	50V	CQSA 352G 50
C90	Electrolytic	2.2	25V	CSZA 2R2M 25
C91	Electrolytic	2.2	25V	CSZA 2R2M 25
C92	Ceramic	220p	50V	CCDSL 221K 50
C93	Ceramic	220p	50V	CCDSL 221K 50
C94	Electrolytic	220	25V	CEA 221P 25
C95	Electrolytic	220	25V	CEA 221P 25
C96	Ceramic	330p	50V	CKDYB 331K 50
C97	Ceramic	330p	50V	CKDYB 331K 50
C98	Mylar	0.022	50V	CQMA 223K 50
C99	Mylar	0.022	50V	CQMA 223K 50
C100	Electrolytic	1	25V	CSZA 010M 25
C101	Electrolytic	47	10V	CEA 470P 10
C102	Ceramic	100p	50V	CCDSL 101K 50
C103	Ceramic	1800p	50V	CKDYB 182K 50
C104	Electrolytic	0.1	35V	CSZA 0R1M 35
C105	Electrolytic	100	35V	CEA 101P 35
C106	Ceramic	0.04	50V	CKDYF 403Z 50
C107	Ceramic	0.04	50V	CKDYF 403Z 50
C108	Mylar	0.047	50V	CQMA 473K 50

12.4 EQUALIZER AMPLIFIER ASSEMBLY (AWK-065)

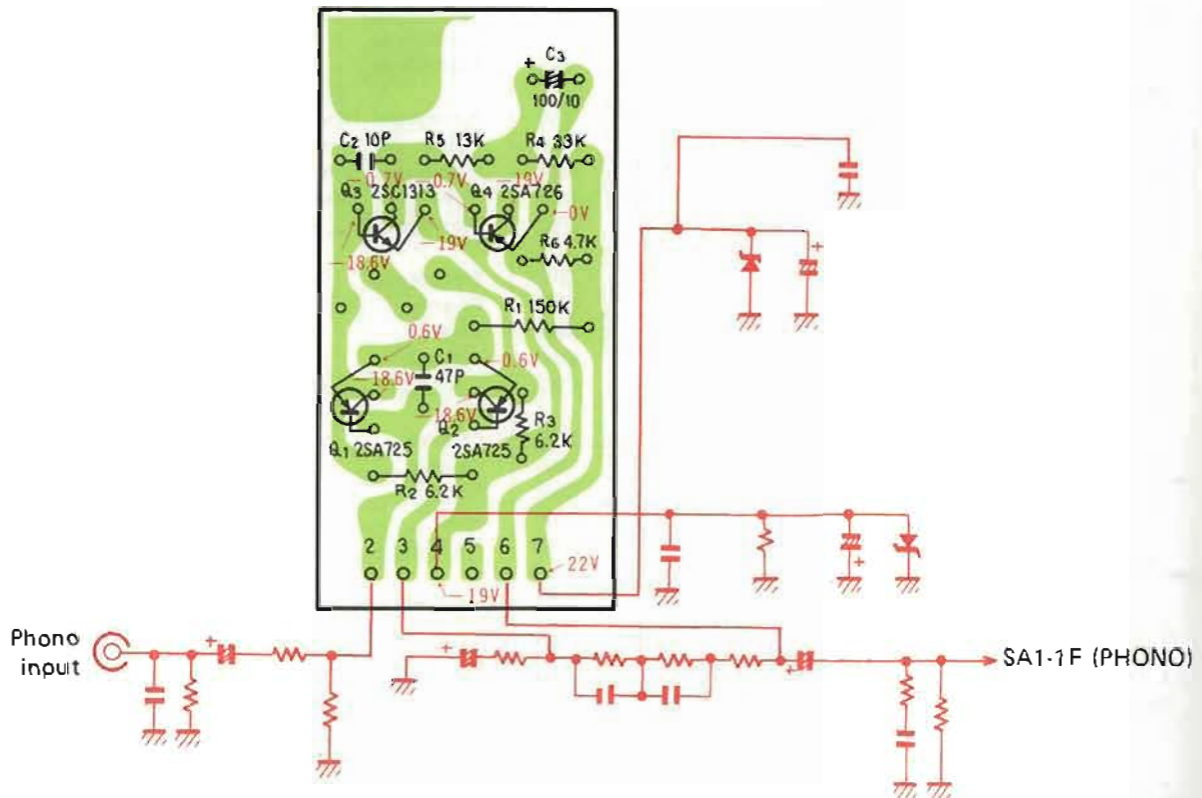
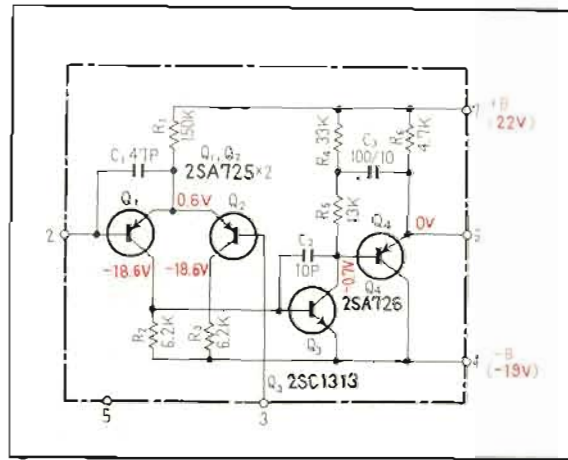

Parts List

SEMICONDUCTORS

Symbol	Description	Part No.
Q1	Transistor	2SA725-G (2SA640-E)
Q2	Transistor	2SA725-G (2SA640-E)
Q3	Transistor	2SC1313-G
Q4	Transistor	2SA726-G (2SA640-E)

RESISTORS

Symbol	Description	Part No.
R1	Carbon film 150k	RD½VS 154J NL
R2	Carbon film 6.2k	RD½VS 622J
R3	Carbon film 6.2k	RD½VS 622J
R4	Carbon film 33k	RD½VS 333J
R5	Carbon film 13k	RD½VS 133J
R6	Carbon film 4.7k	RD½VS 472J

CAPACITORS

Symbol	Description	Part No.
C1	Ceramic 47p 50V	CCDSL 470K 50
C2	Ceramic 10p 50V	CCDSL 100K 50
C3	Electrolytic 100 10V	CEA 101P 10

12.5 TONE CONTROL ASSEMBLY (AWG-049)

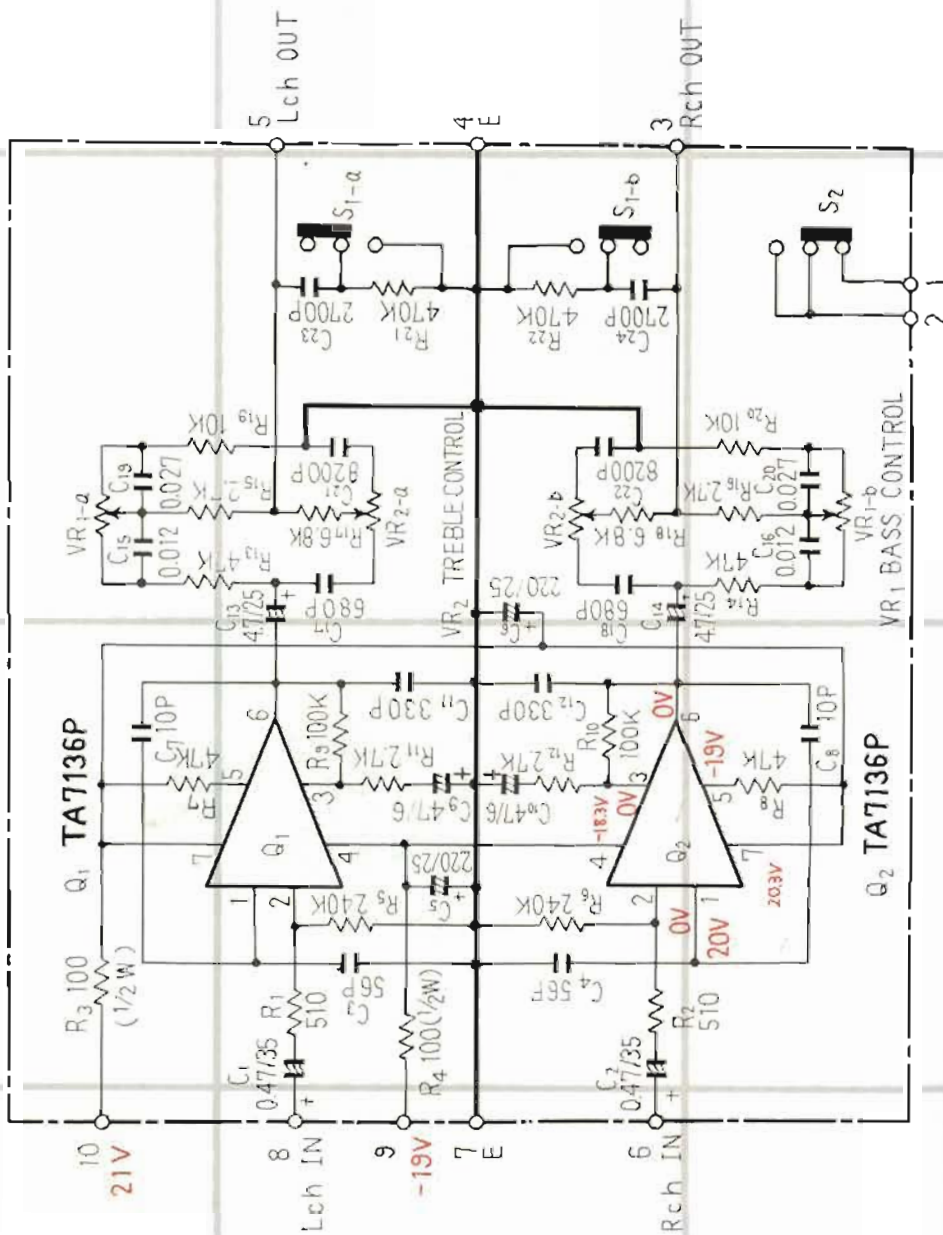

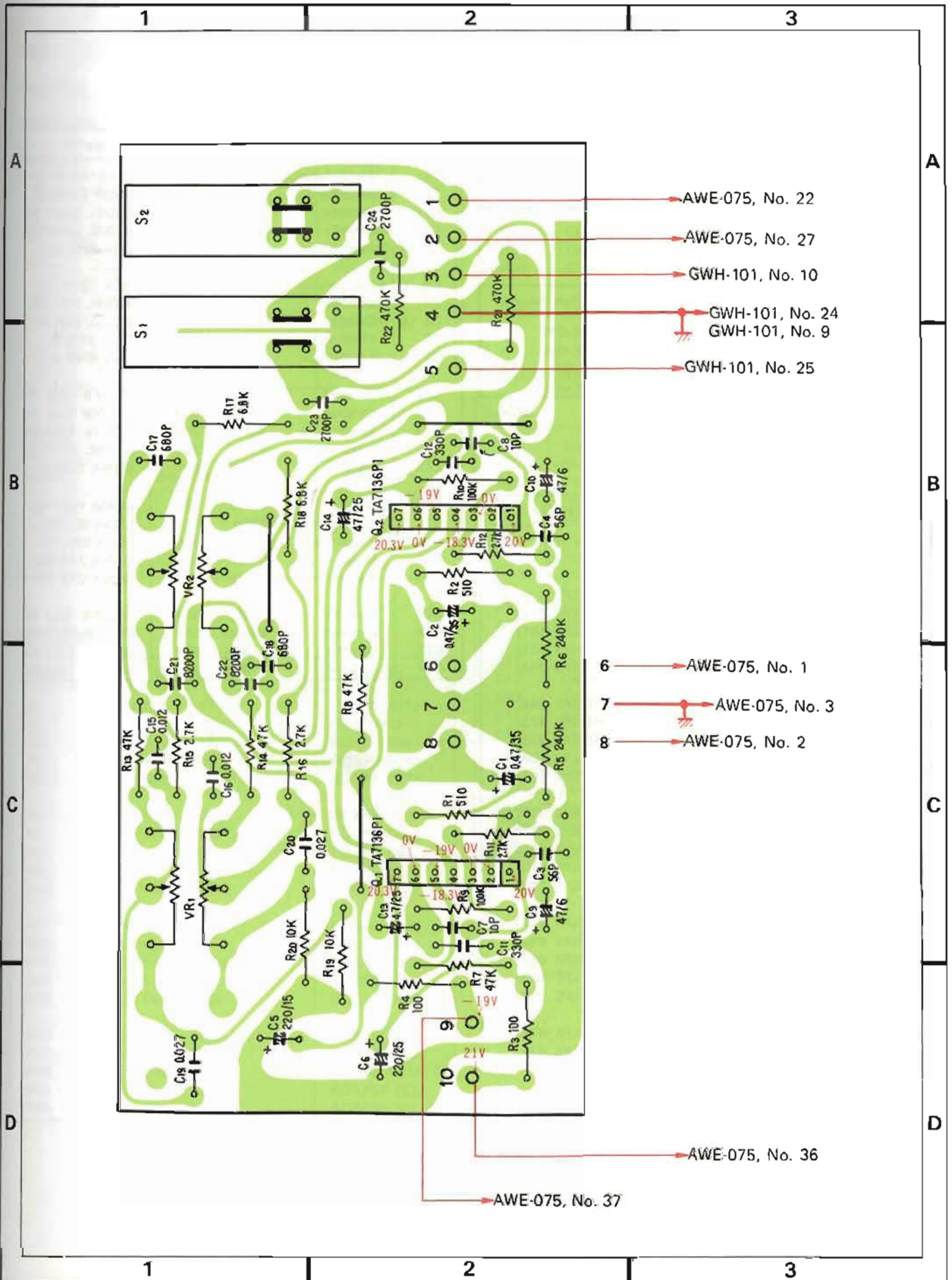

- AWE-075, No. 22
- AWE-075, No. 27
- GWH-101, No. 10
- GWH-101, No. 24
- GWH-101, No. 9
- GWH-101, No. 25

- AWE-075, No. 1
- AWE-075, No. 3
- AWE-075, No. 2

- AWE-075, No. 36
- AWE-075, No. 37

Parts List of Tone Control Assembly (AWG-049)

SEMICONDUCTORS

Symbol	Description	Part No.
Q1	IC	TA7136P
Q2	IC	TA7136P

OTHER

Symbol	Description	Part No.
	Lever switch (HIGH FILTER)	ASK-090
	Lever switch (FM MUTING)	ASK-090
	Nut (9φ)	B71-004
	Inside-toothed washer	ABE-001

RESISTORS

Symbol	Description	Part No.
	Variable (BASS) 50k	ACV-159
	Variable (TREBLE) 50k	ACV-160
R1	Carbon film 510	RD $\frac{1}{2}$ PS 511J
R2	Carbon film 510	RD $\frac{1}{2}$ PS 511J
R3	Carbon film 100 $\frac{1}{2}$ W	RD $\frac{1}{2}$ PS 101J
R4	Carbon film 100 $\frac{1}{2}$ W	RD $\frac{1}{2}$ PS 101J
R5	Carbon film 240k	RD $\frac{1}{2}$ PS 244J
R6	Carbon film 240k	RD $\frac{1}{2}$ PS 244J
R7	Carbon film 47k	RD $\frac{1}{2}$ PS 473J
R8	Carbon film 47k	RD $\frac{1}{2}$ PS 473J
R9	Carbon film 100k	RD $\frac{1}{2}$ PS 104J
R10	Carbon film 100k	RD $\frac{1}{2}$ PS 104J
R11	Carbon film 2.7k	RD $\frac{1}{2}$ PS 272J
R12	Carbon film 2.7k	RD $\frac{1}{2}$ PS 272J
R13	Carbon film 47k	RD $\frac{1}{2}$ PS 473J
R14	Carbon film 47k	RD $\frac{1}{2}$ PS 473J
R15	Carbon film 2.7k	RD $\frac{1}{2}$ PS 272J
R16	Carbon film 2.7k	RD $\frac{1}{2}$ PS 272J
R17	Carbon film 6.8k	RD $\frac{1}{2}$ PS 682J
R18	Carbon film 6.8k	RD $\frac{1}{2}$ PS 682J
R19	Carbon film 10k	RD $\frac{1}{2}$ PS 103J
R20	Carbon film 10k	RD $\frac{1}{2}$ PS 103J
R21	Carbon film 470k	RD $\frac{1}{2}$ PS 474J
R22	Carbon film 470k	RD $\frac{1}{2}$ PS 474J

CAPACITORS

Symbol	Description	Part No.
C1	Electrolytic 0.47 35V	CSZA R47M 35
C2	Electrolytic 0.47 35V	CSZA R47M 25
C3	Ceramic 56p 50V	CCDSL 560K 50
C4	Ceramic 56p 50V	CCDSL 560K 50
C5	Electrolytic 220 25V	CEA 221P 25
C6	Electrolytic 220 25V	CEA 221P 25
C7	Ceramic 10p 50V	CCDSL 100F 50
C8	Ceramic 10p 50V	CCDSL 100F 50
C9	Electrolytic 47 6V	CEA 470P 6
C10	Electrolytic 47 6V	CEA 470P 6
C11	Ceramic 330p 50V	CKDYB 331K 50
C12	Ceramic 330p 50V	CKDYB 331K 50
C13	Electrolytic 4.7 25V	CEANL 4R7P 25
C14	Electrolytic 4.7 25V	CEANL 4R7P 25
C15	Mylar 0.012 50V	QOMA 123J 50
C16	Mylar 0.012 50V	QOMA 123J 50
C17	Polystyrene film 680p 50V	QOSA 681J 50
C18	Polystyrene film 680p 50V	QOSA 681J 50
C19	Mylar 0.027 50V	QOMA 273J 50
C20	Mylar 0.027 50V	QOMA 273J 50
C21	Ceramic 8200p 50V	CKDYA 822J 50
C22	Ceramic 8200p 50V	CKDYA 822J 50
C23	Ceramic 2700p 50V	CKDYA 272J 50
C24	Ceramic 2700p 50V	CKDYA 272J 50

12.6 POWER AMPLIFIER ASSEMBLY 1 (GWH-101)

Parts List

SEMICONDUCTORS

Symbol	Description	Part No.
Q1	Transistor	2SA798-F (2SA842-GR)
Q2	Transistor	2SA798-F (2SA842-GR)
Q3	Transistor	2SC1438-V (2SC1451-B)
Q4	Transistor	2SC1438-V (2SC1451-B)
D1	Diode	1S2473
D2	Diode	1S2473

Symbol	Description	Part No.
R21	Carbon film 3.9k	RD½PS 392J
R22	Carbon film 3.9k	RD½PS 392J
R23	Carbon film 10 ½W	RD½PSF 100J
R24	Carbon film 10 ½W	RD½PSF 100J
R25	Carbon film 10 ½W	RD½PSF 100J
R26	Carbon film 10 ½W	RD½PSF 100J

CAPACITORS

Symbol	Description	Part No.
C1	Electrolytic 1 25V	CSZA 010M 25
C2	Electrolytic 1 25V	CSZA 010M 25
C3	Ceramic 56p 50V	CCDSL 560K 50
C4	Ceramic 56p 50V	CCDSL 560K 50
C5	Ceramic 68p 50V	CCDSL 680K 50
C6	Ceramic 68p 50V	CCDSL 680K 50
C7	Electrolytic 220 6V	CEA 221P 6
C8	Electrolytic 220 6V	CEA 221P 6
C9	Electrolytic 47 35V	CEA 470P 35
C10	Electrolytic 47 35V	CEA 470P 35
C11	Ceramic 15p 50V	CCDSL 150K 50
C12	Ceramic 15p 50V	CCDSL 150K 50
C13	Electrolytic 220 6V	CEA 221P 6
C14	Electrolytic 220 6V	CEA 221P 6
C15	Ceramic 180p 500V	CCDSL 181K 500
C16	Ceramic 180p 500V	CCDSL 181K 500
C17	Ceramic 180p 500V	CCDSL 181K 500
C18	Ceramic 180p 500V	CCDSL 181K 500
C19	Ceramic 0.04 50V	CKDYF 403Z 50
C20	Ceramic 0.04 50V	CKDYF 403Z 50

OTHERS

Symbol	Description	Part No.
L1	AF choke coil	T63-009
L2	AF choke coil	T63-009
S1	Relay	ASR-018

RESISTORS

Symbol	Description	Part No.
R1	Carbon film 470 ½W	RD½PS 471J
R2	Metal oxide film 430 1W	RS1P 431J
R3	Carbon film 560k	RD½PS 564J
R4	Carbon film 560k	RD½PS 564J
R5	Carbon film 2.2k	RD½PS 222J
R6	Carbon film 2.2k	RD½PS 222J
R7	Carbon film 56k	RD½PS 563J
R8	Carbon film 56k	RD½PS 563J
R9	Carbon film 56k	RD½PS 563J
R10	Carbon film 56k	RD½PS 563J
R11	Carbon film 2k	RD½PS 202J
R12	Carbon film 2k	RD½PS 202J
R13	Carbon film 1.2k	RD½VS 122J
R14	Carbon film 1.2k	RD½PS 122J
R15	Carbon film 30k	RD½VS 303J
R16	Carbon film 30k	RD½PS 303J
R17	Carbon film 1.8k ½W	RD½PS 182J
R18	Carbon film 1.8k ½W	RD½PS 182J
R19	Carbon film 100	RD½PSF 101J
R20	Carbon film 100	RD½PSF 101J

Power Amplifier Assembly 1 (GWH-101)

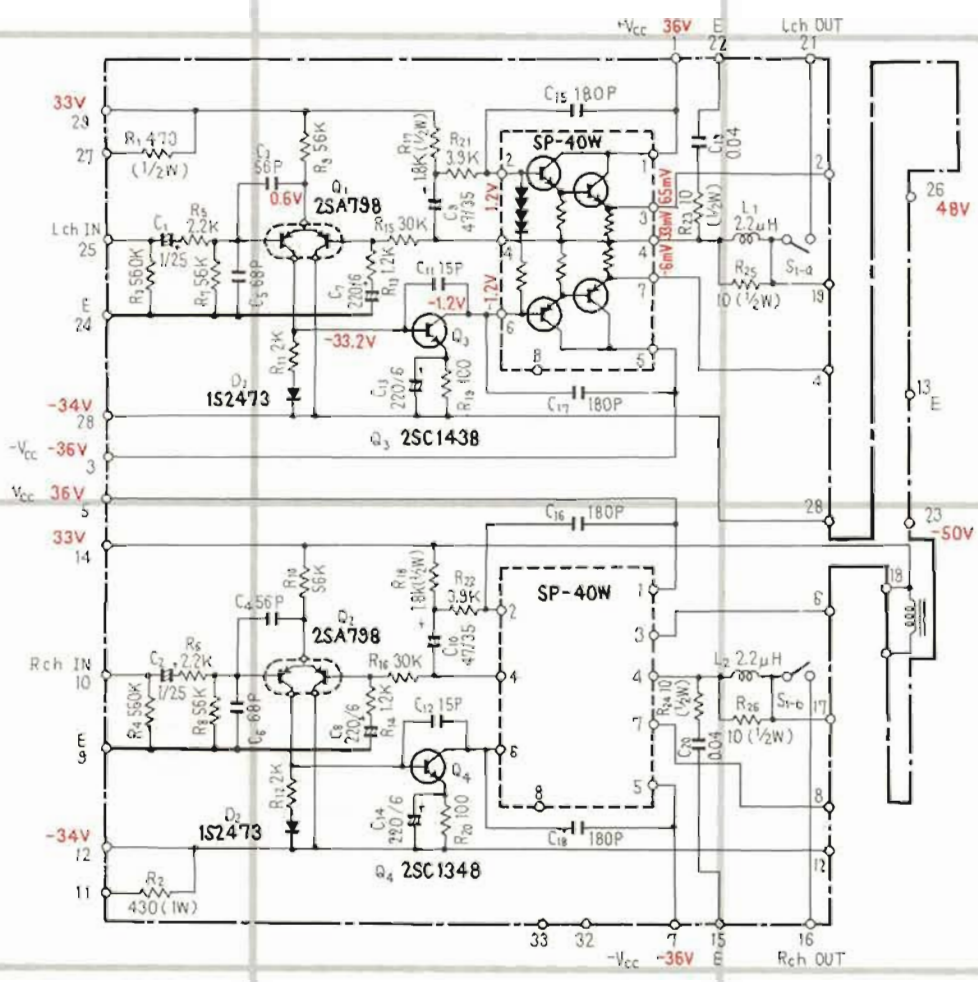

A

B

C

D

A

B

C

D

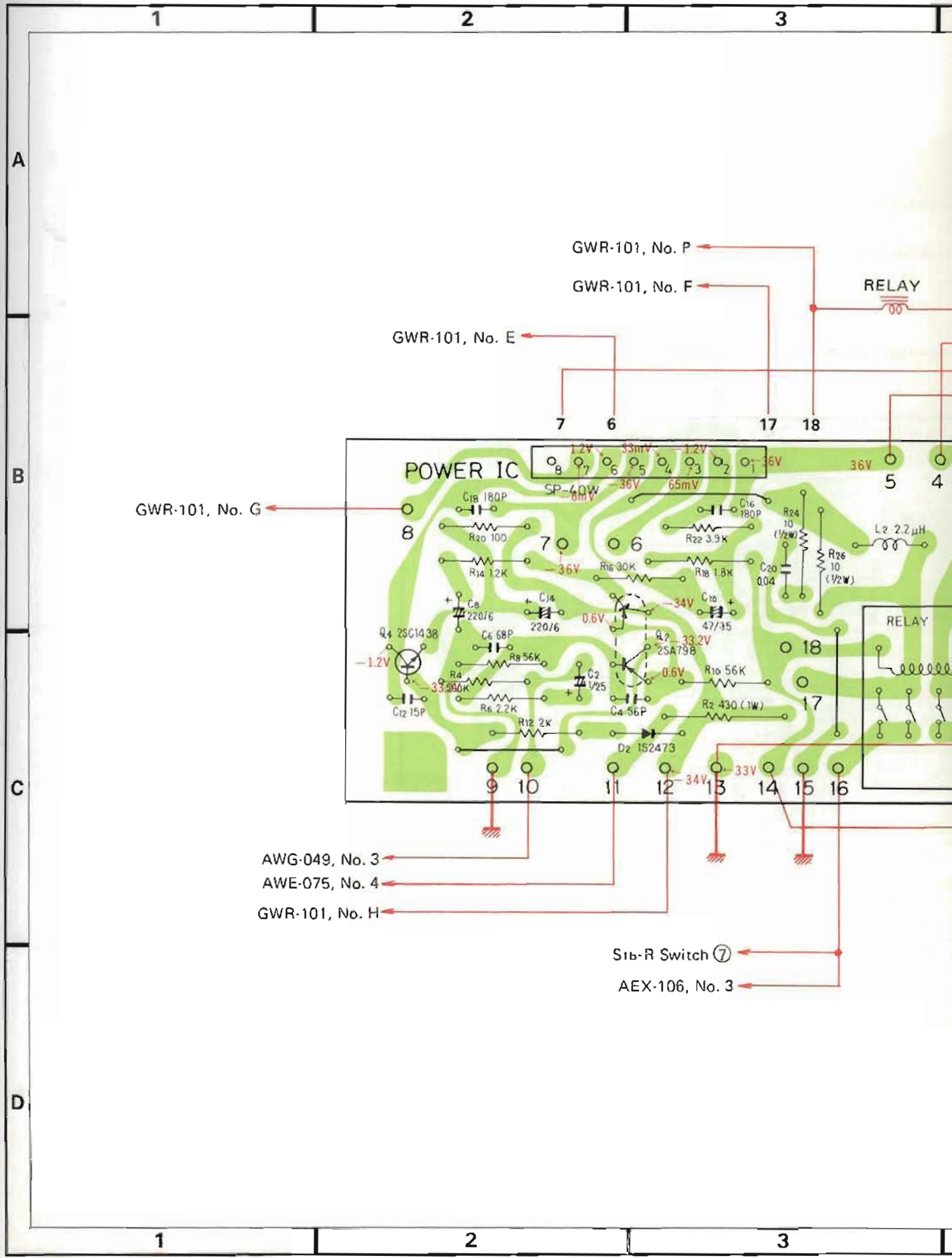

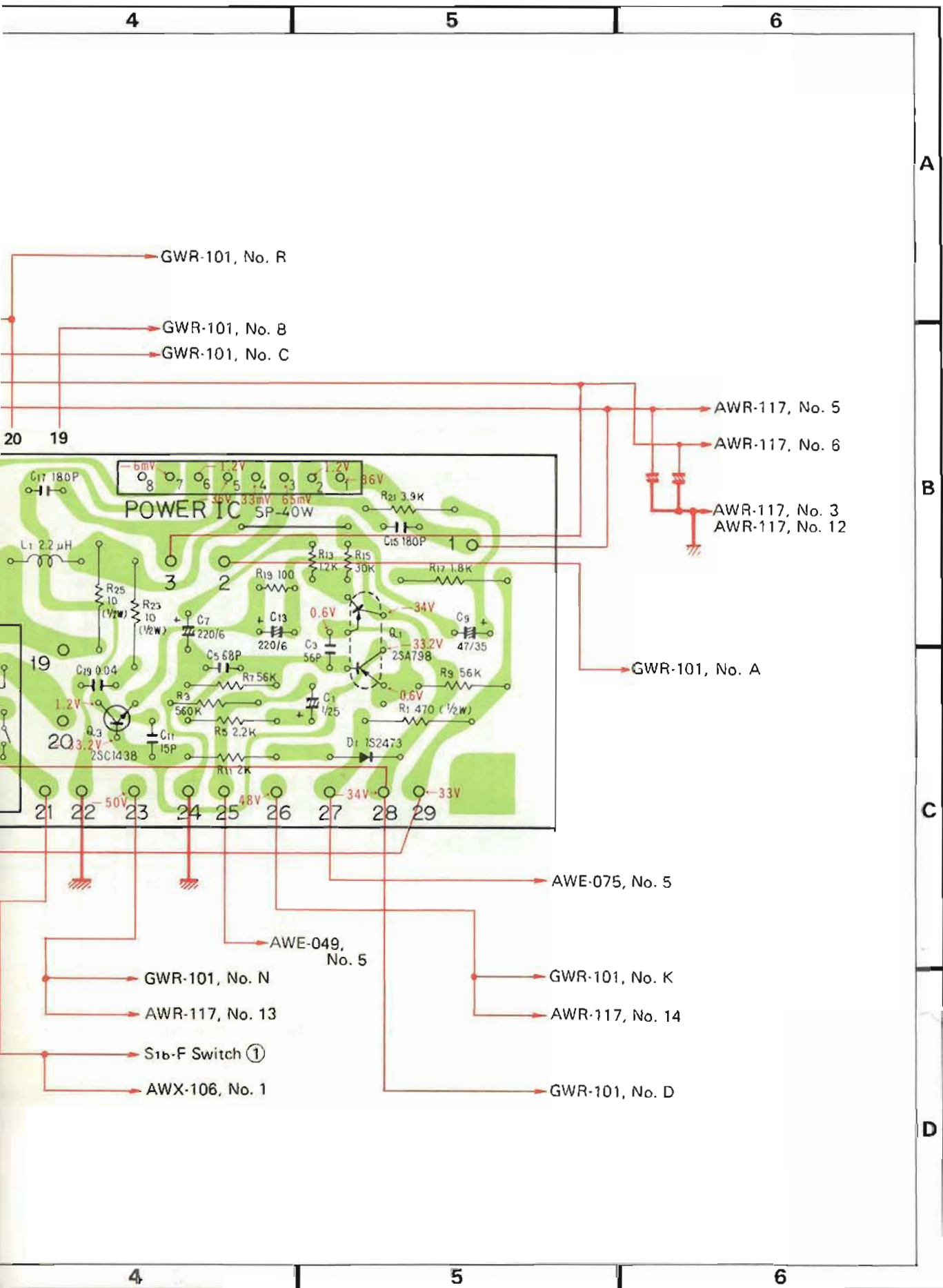

A

B

C

D

4

5

6

4

5

6

12.7 POWER AMPLIFIER ASSEMBLY 2 (GWR-101)

A

B

C

D

1

2

3

1

2

3

GWH-101, No. 8

GWH-101, No. 6

GWH-101, No. 19

GWH-101, No. 17

E

A

R

GWH-101, No. 12

AWR-117, No. 10

GWR-101, No. 31

DIAL ILLUMINATE POWER IND

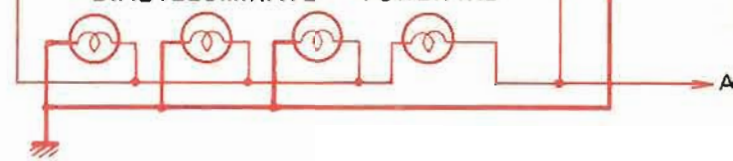
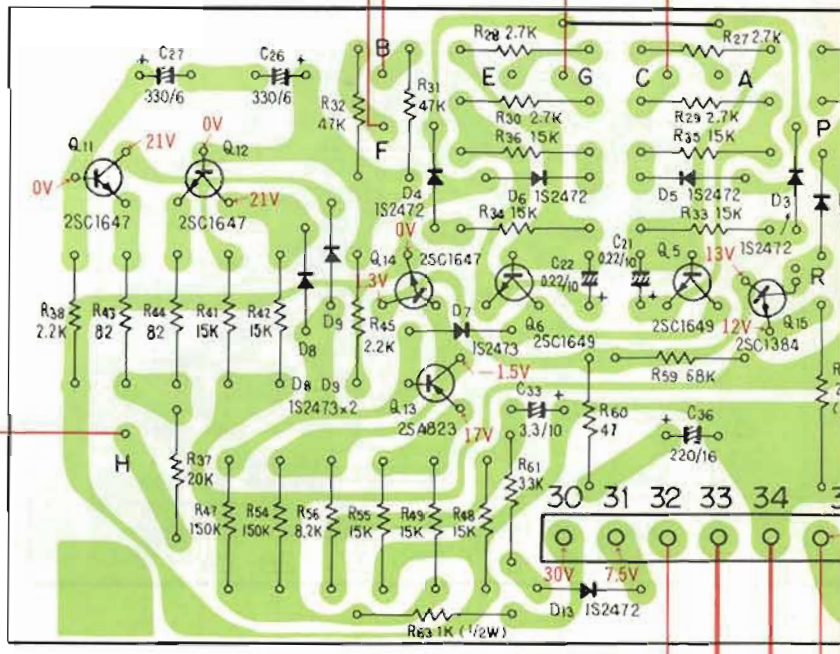

4

5

6

A

B

C

D

- GWH-101, No. 4
- GWH-101, No. 2
- GWH-101, No. 20
- GWH-101, No. 18
- GWH-101, No. 23
- GWH-101, No. 13
- GWH-101, No. 26
- GWH-101, No. 28

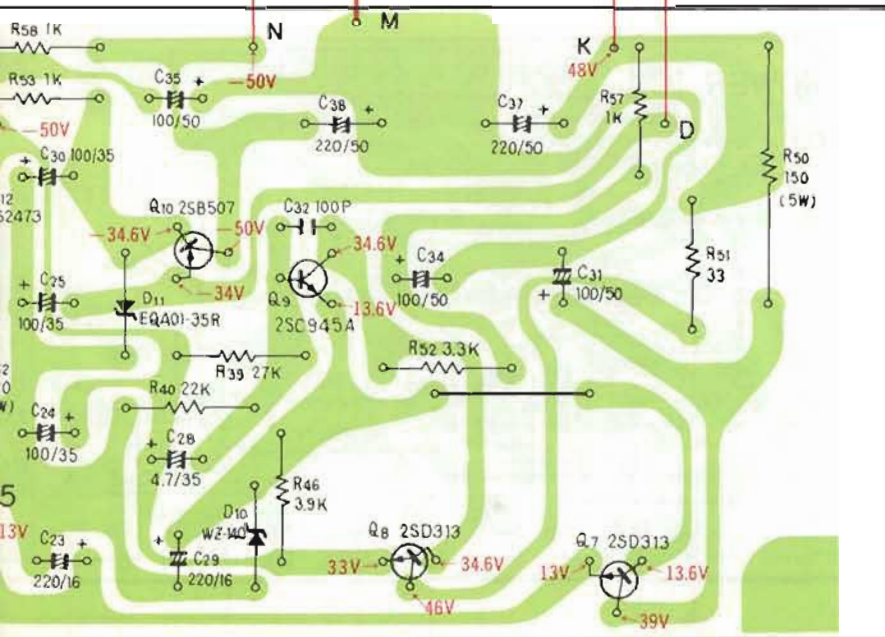

→ AWE-075, No. 12

→ AWE-075, No. 20

STEREO IND

WX-106, No. 2

4

5

6

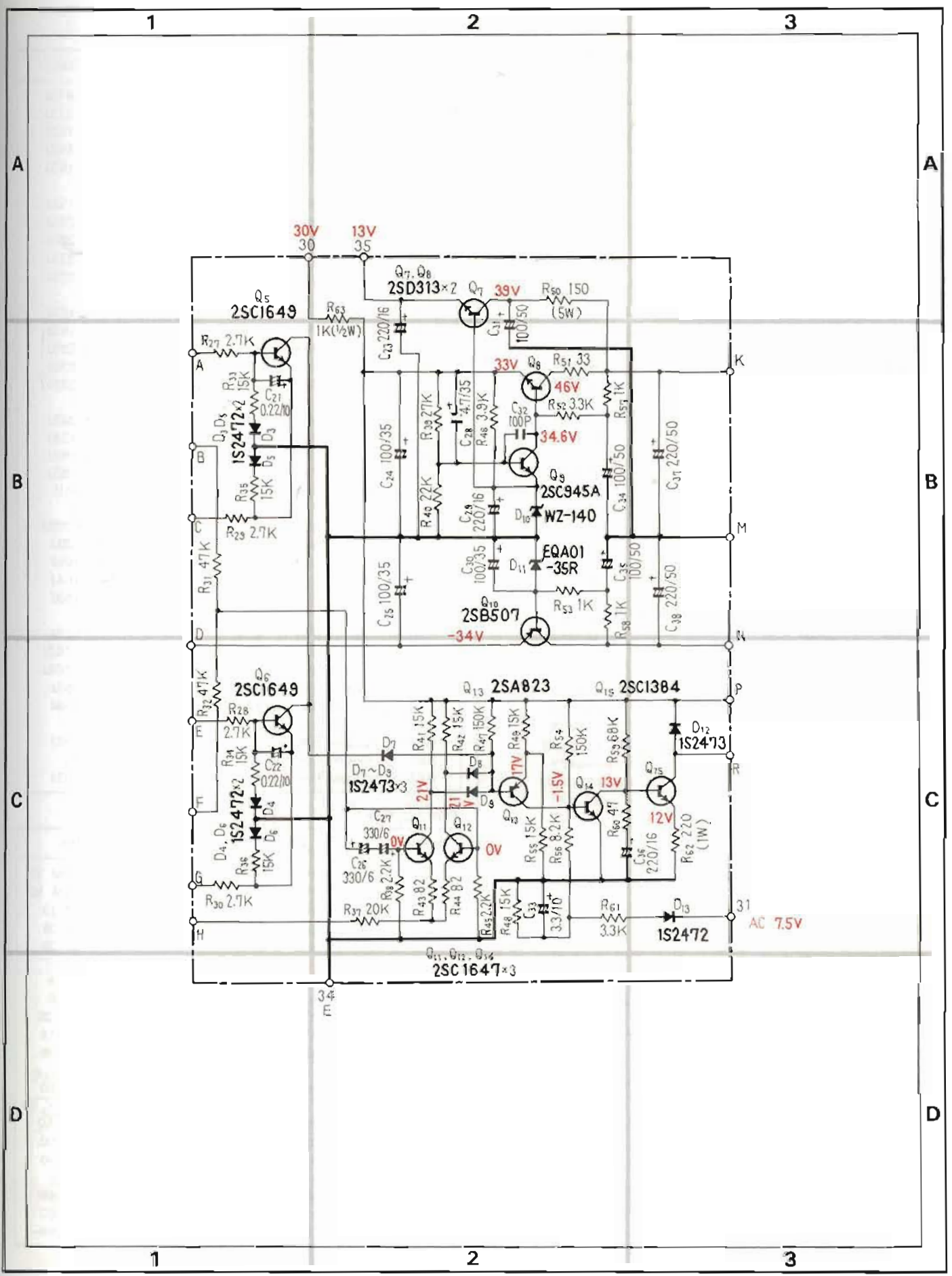

Parts List of Power Amplifier Assembly 2 (GWR-101)

SEMICONDUCTORS

Symbol	Description	Part No.
Q5	Transistor	2SC1649-N (2SC869-C)
Q6	Transistor	2SC1649-N (2SC869-C)
Q7	Transistor	2SD313-D (2SD526-R)
Q8	Transistor	2SD313-D (2SD526-R)
Q9	Transistor	2SC945A-Q
Q10	Transistor	2SB507-D (2SB596-R)
Q11	Transistor	2SC1647-P (2SC945A-Q)
Q12	Transistor	2SC1647-P (2SC945A-Q)
Q13	Transistor	2SA823-P (2SA733-Q)
Q14	Transistor	2SC1647-P (2SC945A-Q)
Q15	Transistor	2SC1384-Q (2SC1166-Y)
D3	Diode	1S2472 (1S1554)
D4	Diode	1S2472 (1S1554)
D5	Diode	1S2472 (1S1554)
D6	Diode	1S2472 (1S1554)
D7	Diode	1S2473 (1S1555)
D8	Diode	1S2473 (1S1555)
D9	Diode	1S2473 (1S1555)
D10	Zener diode	WZ-140
D11	Zener diode	EQA01-35R
D12	Diode	1S2473 (1S1555)
D13	Diode	1S2472 (1S1554)

OTHERS

Symbol	Description	Part No.
	Heat sink	ANH-259
	Insulator pipe	ADX-016

RESISTORS

Symbol	Description	Part No.
R27	Carbon film 2.7k	RD½PS 272J
R28	Carbon film 2.7k	RD½PS 272J
R29	Carbon film 2.7k	RD½PS 272J
R30	Carbon film 2.7k	RD½PS 272J

Symbol	Description	Part No.
R31	Carbon film 47k	RD½PS 473J
R32	Carbon film 47k	RD½PS 473J
R33	Carbon film 15k	RD½PS 153J
R34	Carbon film 15k	RD½PS 153J
R35	Carbon film 15k	RD½PS 153J
R36	Carbon film 15k	RD½PS 153J
R37	Carbon film 20k	RD½PS 203J
R38	Carbon film 2.2k	RD½PS 222J
R39	Carbon film 27k	RD½PS 273J
R40	Carbon film 22k	RD½PS 223J
R41	Carbon film 15k	RD½PS 153J
R42	Carbon film 15k	RD½PS 153J
R43	Carbon film 82	RD½PS 820J
R44	Carbon film 82	RD½PS 820J
R45	Carbon film 2.2k	RD½PS 222J
R46	Carbon film 3.9k	RD½PS 392J
R47	Carbon film 150k	RD½PS 154J
R48	Carbon film 15k	RD½PS 153J
R49	Carbon film 15k	RD½PS 153J
R50	Wire wound 150 SW	RT5B 151K
R51	Carbon film 33	RD½PSF 330J
R52	Carbon film 3.3k	RD½PS 332J
R53	Carbon film 1k	RD½PS 102J
R54	Carbon film 150k	RD½PS 154J
R55	Carbon film 15k	RD½PS 153J
R56	Carbon film 8.2k	RD½PS 822J
R57	Carbon film 1k	RD½PSF 102J
R58	Carbon film 1k	RD½PSF 102J
R59	Carbon film 68k	RD½PS 683J
R60	Carbon film 47	RD½PS 470J
R61	Carbon film 3.3k	RD½PS 332J
R62	Metal oxide 220 1W	RS1P 221J
R63	Carbon film 1k ½W	RD½PS 102J

CAPACITOR

Symbol	Description	Part No.
C21	Electrolytic 0.22 10V	CSSA R22M 10
C22	Electrolytic 0.22 10V	CSSA R22M 10
C23	Electrolytic 220 16V	CEA 221P 16
C24	Electrolytic 100 35V	CEA 101P 35
C25	Electrolytic 100 35V	CEA 101P 35
C26	Electrolytic 330 6V	CEA 331P 6
C27	Electrolytic 330 6V	CEA 331P 6
C28	Electrolytic 4.7 35V	CEA 4R7P 35
C29	Electrolytic 220 16V	CEA 221P 16
C30	Electrolytic 100 35V	CEA 101P 35
C31	Electrolytic 100 50V	CEA 101P 50
C32	Ceramic 100p 50V	CCDSL 101K 50
C33	Electrolytic 3.3 50V	CEA 3R3P 50
C34	Electrolytic 100 50V	CEA 101P 50
C35	Electrolytic 100 50V	CEA 101P 50
C36	Electrolytic 220 16V	CEA 221P 16
C37	Electrolytic 220 50V	CEA 221P 50
C38	Electrolytic 220 50V	CEA 221P 50

12.8 HEADPHONE ASSEMBLY (AWX-106)

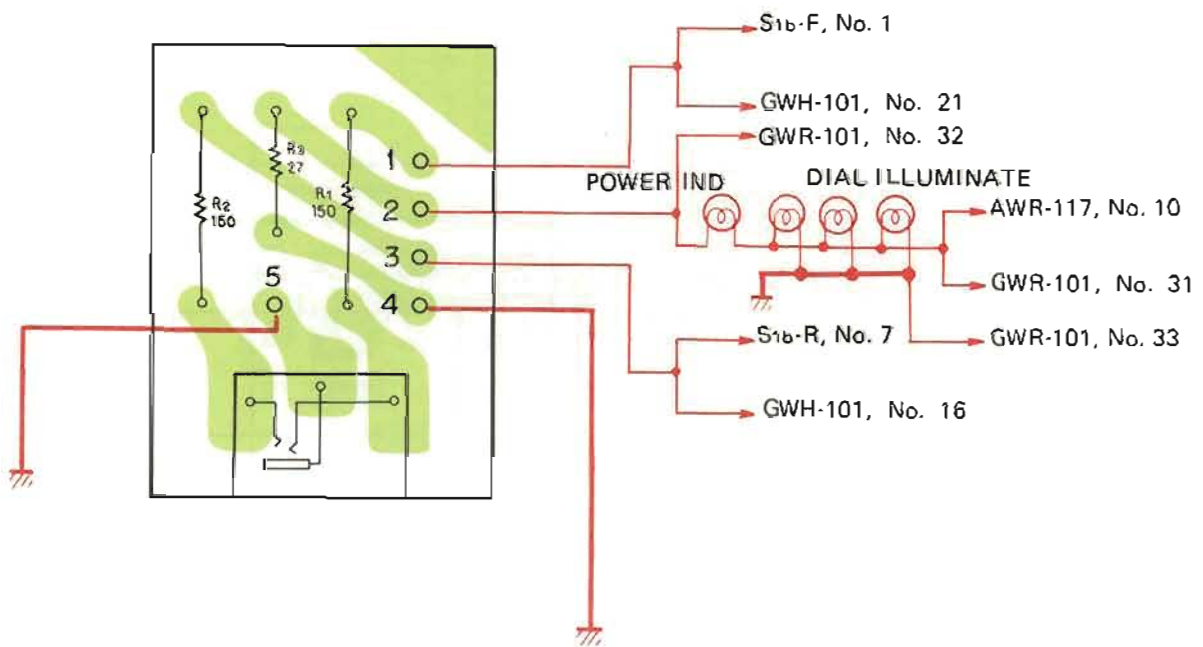
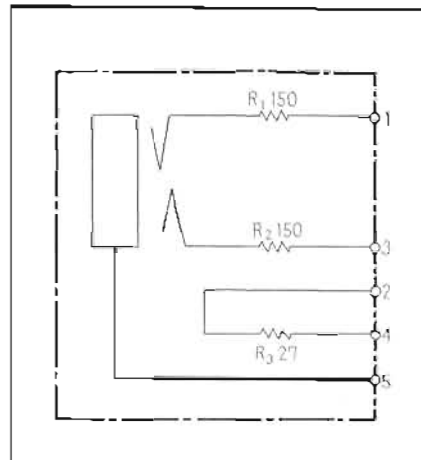

Parts List

Symbol	Description	Part No.
	Headphone jack	AKN-009
R1	Metal oxide film 150 2W	RS2P 151J
R2	Metal oxide film 150 2W	RS2P 151J
R3	Carbon film 27	RD¼PS 270J

12.9 DE-EMPHASIS SWITCH ASSEMBLY (AWX-095)

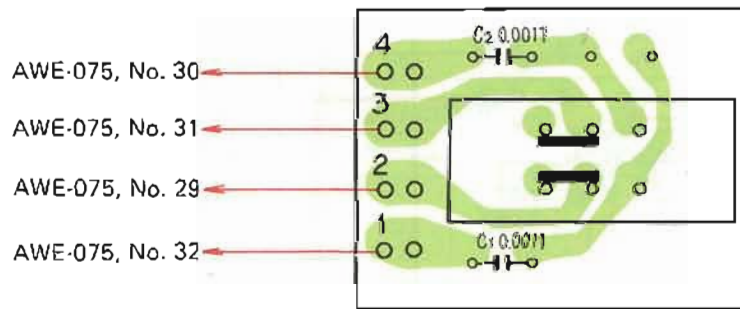
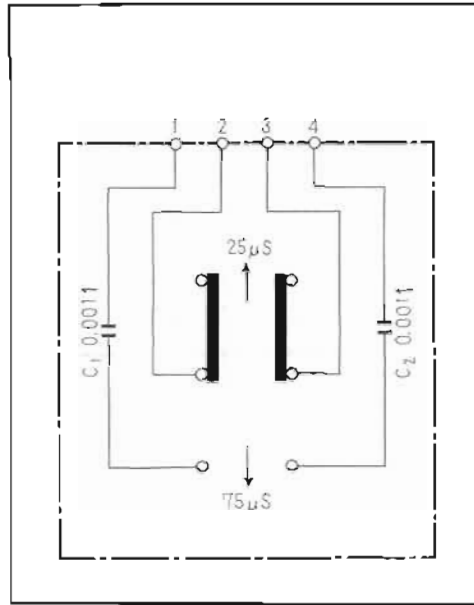

Parts List CAPACITORS

Symbol	Description			Part No.
C1	Mylar	1100p	50V	CQMA 112J 50
C2	Mylar	1100p	50V	CQMA 112J 50
	Slide switch			ASH-015-0

12.10 POWER SUPPLY ASSEMBLY (AWR-117)

Parts List

SEMICONDUCTORS

Symbol	Description	Part No.
D1	Diode	1S1886
D2	Diode	(S1B01-02) 1S1886
D3	Diode	(S1B01-02) 1S1886
D4	Diode	(S1B01-02) 1S1886
D5	Diode	SR3AM-4
D6	Diode	SR3AM-4
D7	Diode	SR3AM-4
D8	Diode	SR3AM-4

OTHERS

Symbol	Description	Part No.
	Fuse clip	AKR-013
	Fuse clip	AKR-030

RESISTORS

Symbol	Description	Part No.
R1	Metal oxide film 4.7k 2W	RS2P 472K
R2	Metal oxide film 4.7k 2W	RS2P 472K

CAPACITORS

Symbol	Description	Part No.
C1	Ceramic 0.01 150V	ACG-004
C2	Ceramic 0.01 150V	ACG-004
C3	Ceramic 0.01 150V	ACG-004
C4	Ceramic 0.01 150V	ACG-004
C5	Ceramic 0.01 150V	ACG-004
C6	Ceramic 0.01 150V	ACG-004
C7	Ceramic 0.01 150V	ACG-004
C8	Ceramic 0.01 150V	ACG-004

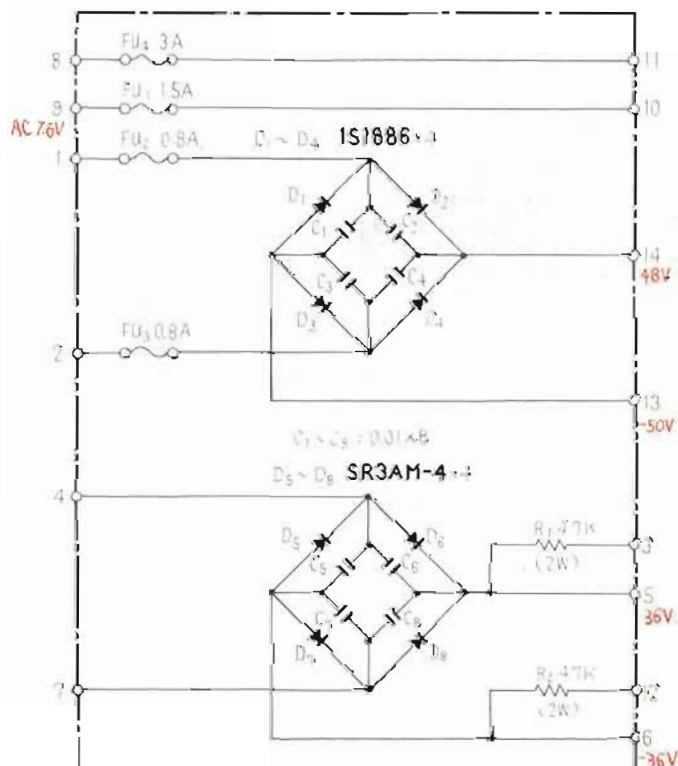

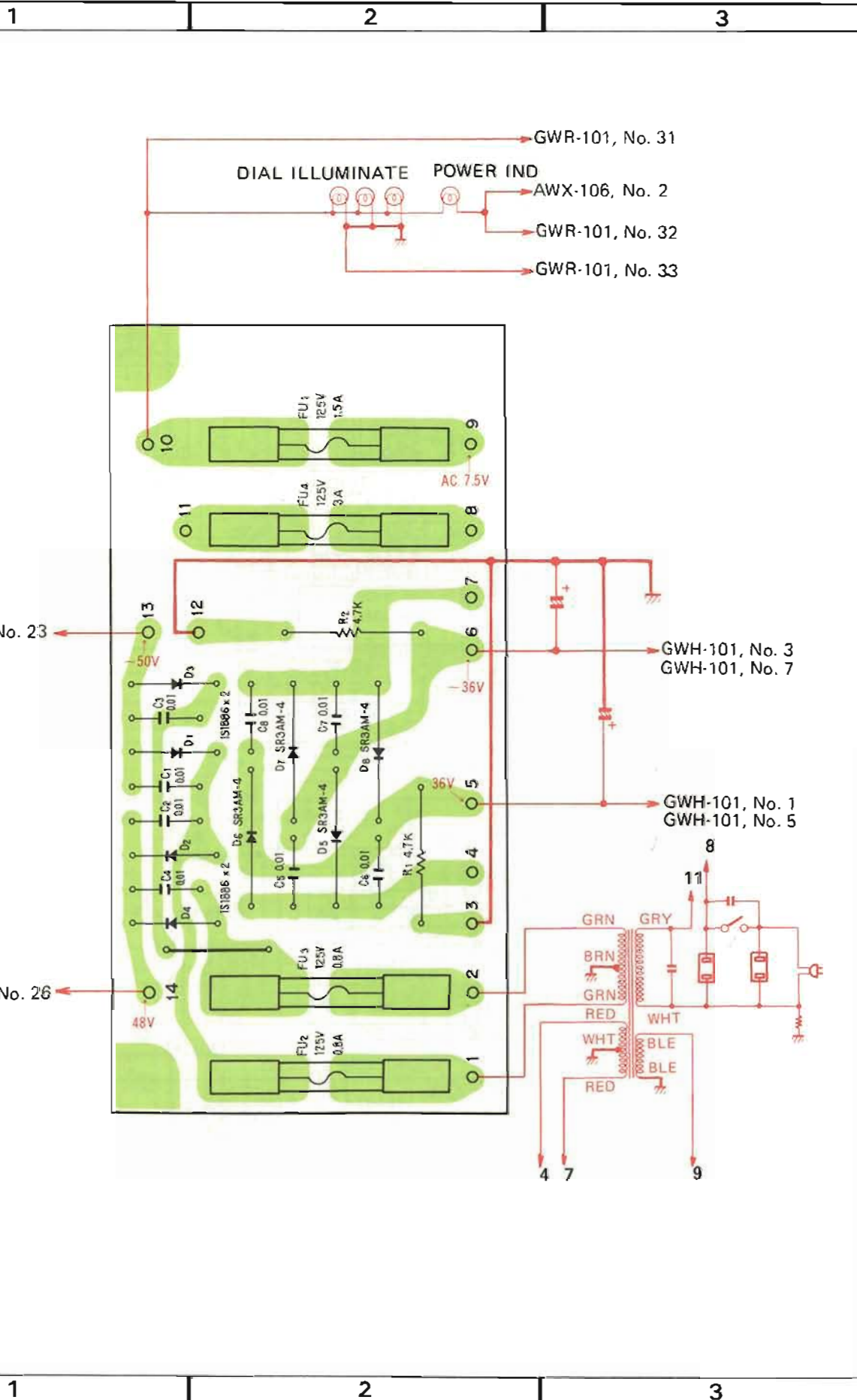

A A
B B
C C
D D

12:11 TUNER AND AF ASSEMBLY (AWE-075)

NOTE: Discrete components may also be used in the equalizer amplifier in place of the IC shown on this diagram.

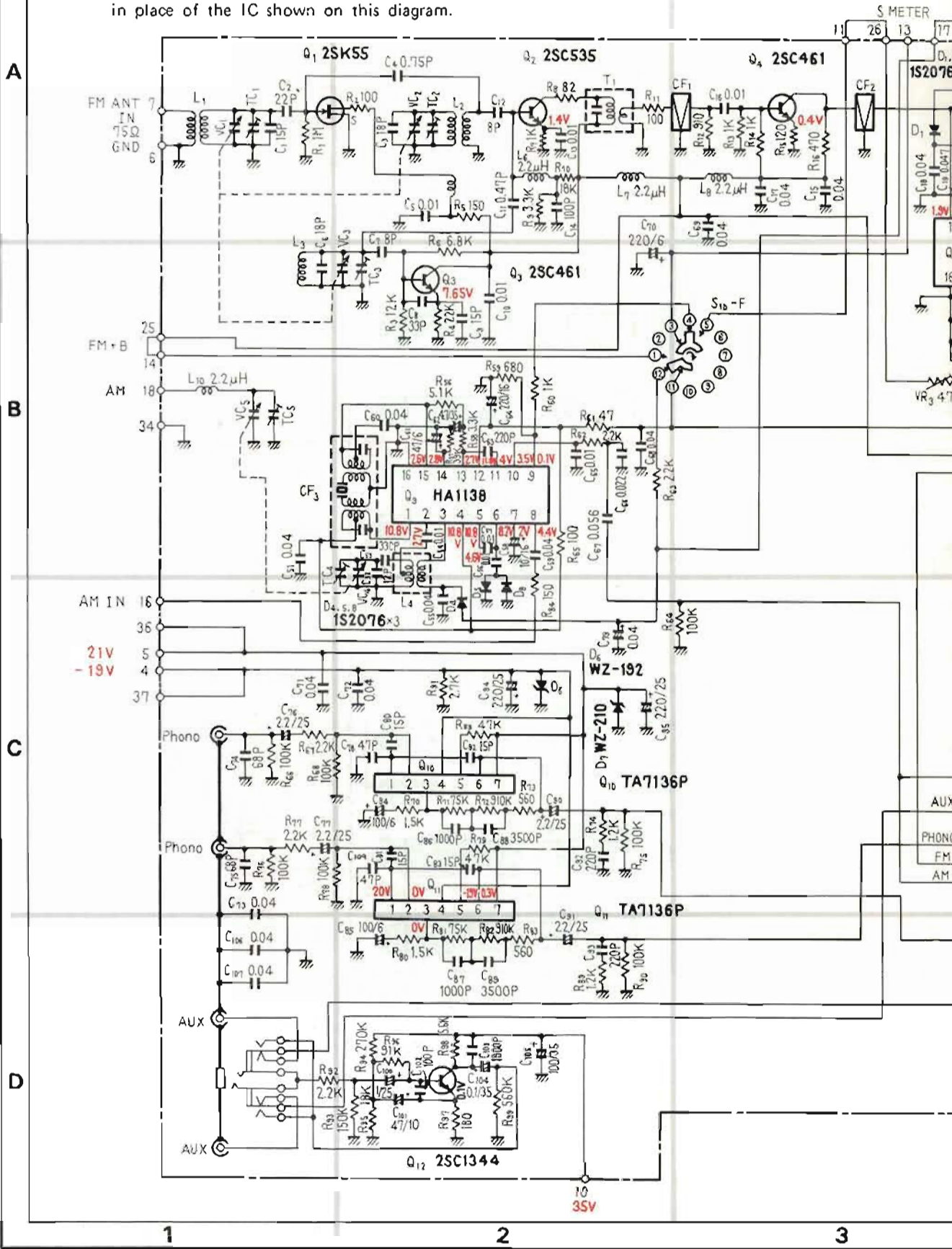

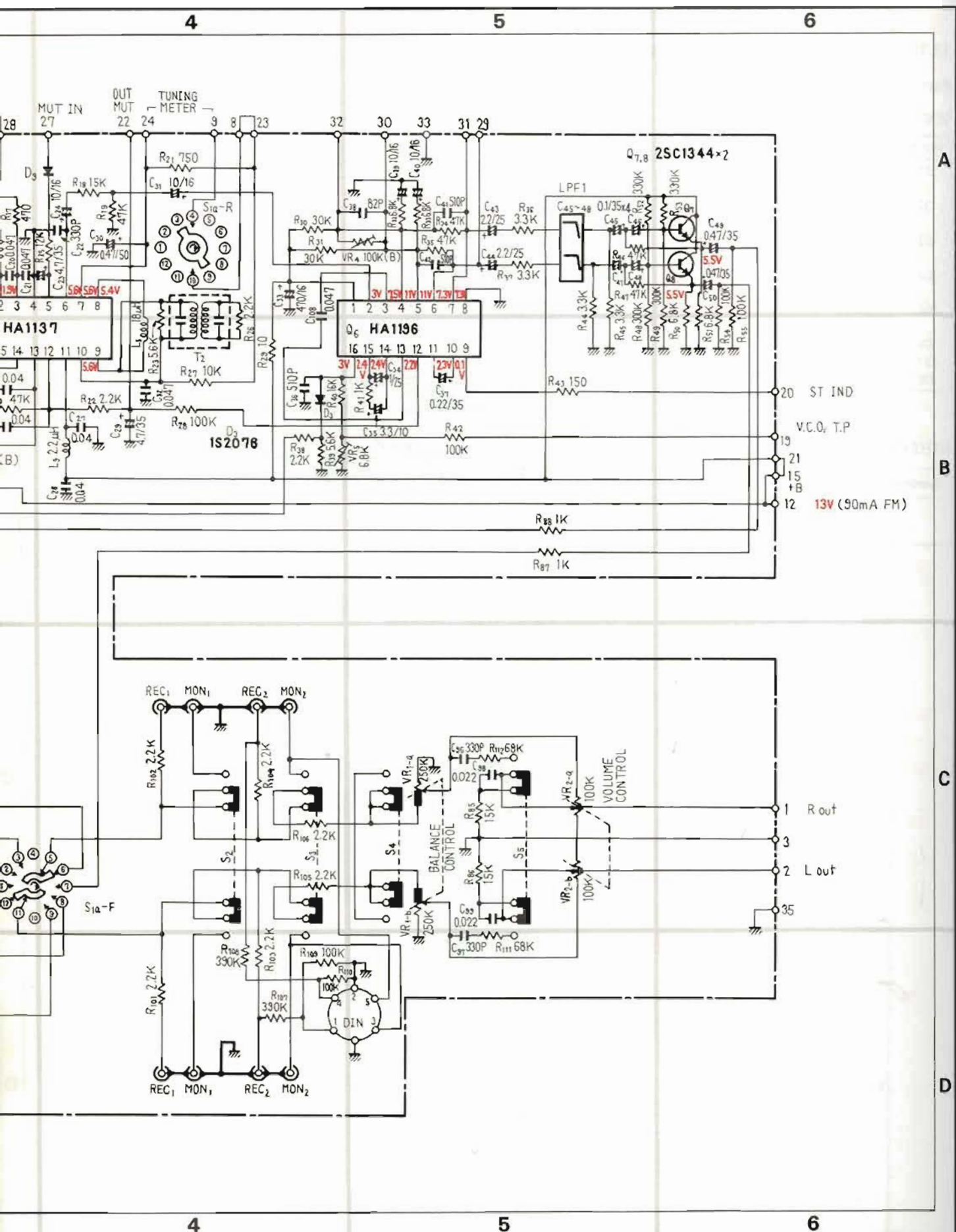

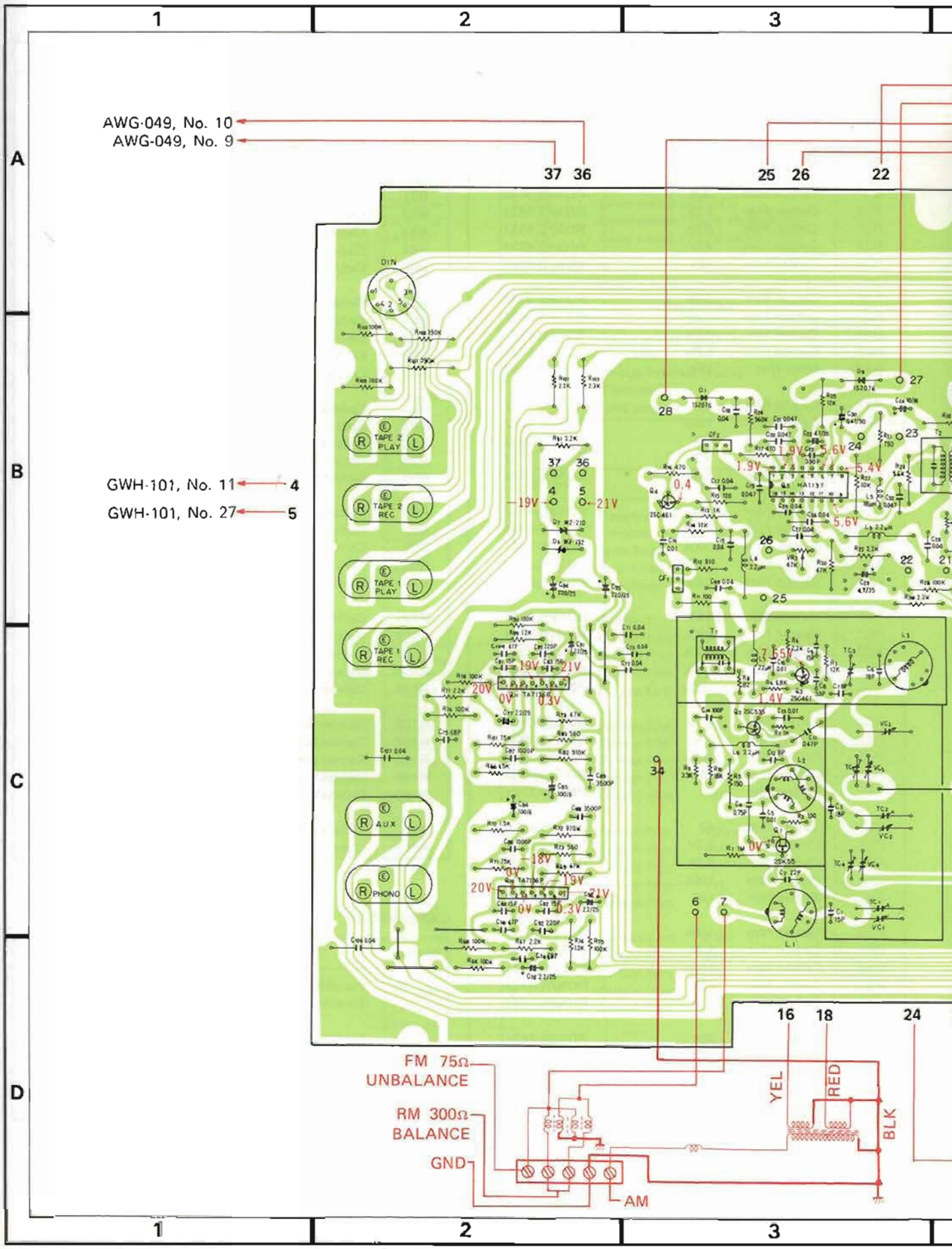

AWG-049, No. 10
 AWG-049, No. 9

37 36 25 26 22

GWH-101, No. 11 → 4
 GWH-101, No. 27 → 5

FM 75Ω
 UNBALANCE

RM 300Ω
 BALANCE

GND

16 18 24

YEL
 RED
 BLK

AM

1 2 3

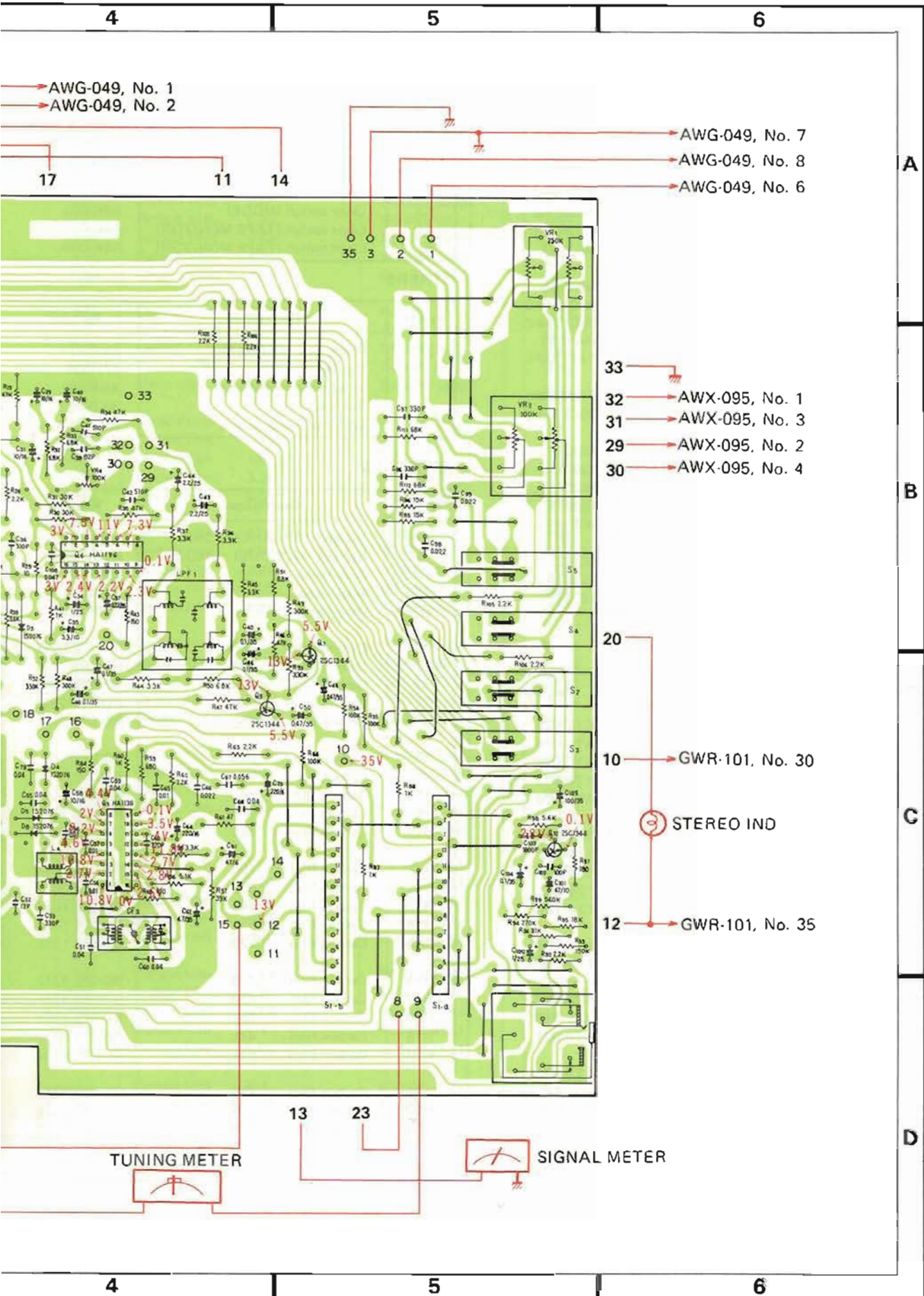

AWG-049, No. 1
AWG-049, No. 2

AWG-049, No. 7
AWG-049, No. 8
AWG-049, No. 6

AWX-095, No. 1
AWX-095, No. 3
AWX-095, No. 2
AWX-095, No. 4

GWR-101, No. 30

STEREO IND

GWR-101, No. 35

TUNING METER

SIGNAL METER

A

B

C

D

4

5

6

Parts List of Tuner and AF Assembly (AWE-075)

SEMICONDUCTORS

Symbol	Description	Part No.
Q1	Transistor	2SK55-D
Q2	Transistor	2SC535-A
Q3	Transistor	2SC461-B
Q4	Transistor	2SC461-B
Q5	IC	HA1137
Q6	IC	HA1196
Q7	Transistor	2SC1344-D
Q8	Transistor	2SC1344-D
Q9	IC	HA1138
Q10	IC	TA7136P1
Q11	IC	TA7136P1
Q12	Transistor	2SC1344-D
D1	Diode	1S2076
D3	Diode	1S2076
D4	Diode	1S2076
D5	Diode	1S2076
D6	Zener diode	WZ-192
D7	Zener diode	MZ322-A
D8	Diode	1S2076
D9	Diode	1S2076

TRANSFORMERS AND COILS

Symbol	Description	Part No.
L1	FM antenna coil	ATC-023
L2	FM RF coil	ATC-024
L3	FM oscillator coil	ATC-025
L4	AM oscillator coil	ATB-013
L5	Micro inductor	ATH-007
L6	RF choke coil	T24-028
L7	RF choke coil	T24-028
L8	RF choke coil	T24-028
L9	RF choke coil	T24-028
L10	RF choke coil	T24-028
T1	FM matching transformer	ATE-008
T2	FM IF transformer	T73-035
CF1	FM ceramic filter	ATF-013
CF2	FM ceramic filter	ATF-013
CF3	AM ceramic filter	ATF-027
LPF1	Low pass filter	ATF-033

SWITCHES

Symbol	Description	Part No.
S1	Rotary switch (FUNCTION)	ASD-049
S2	Lever switch (LOUDNESS)	ASK-090
S3	Lever switch (MODE)	ASK-090
S4	Lever switch (TAPE MONITOR)	ASK-090
S5	Lever switch (TAPE MONITOR)	ASK-090

OTHERS

Symbol	Description	Part No.
J1	Phone jack (PHONES)	AKN-011
	Nut (M9)	B71-004
	In side-toothed washer	ABE-001
	Terminal	AKB-027
	DIN connector socket	AKP-011

RESISTORS

Symbol	Description	Part No.
VR1	Variable (BALANCE) 250k	ACV-136
VR2	Variable (VOLUME) 100k	ACV-179
VR3	Semi-fixed	C92-048
VR4	Semi-fixed	C92-047
VR5	Semi-fixed	ACP-023
R1	Carbon film 1M	RD $\frac{1}{2}$ PS 105J
R2	Carbon film 100	RD $\frac{1}{2}$ VS 101J
R3	Carbon film 12k	RD $\frac{1}{2}$ VS 123J
R4	Carbon film 2.2k	RD $\frac{1}{2}$ VS 222J
R5	Carbon film 150	RD $\frac{1}{2}$ PS 161J
R6	Carbon film 6.8k	RD $\frac{1}{2}$ VS 682J
R7	Carbon film 1k	RD $\frac{1}{2}$ VS 102J
R8	Carbon film 82	RD $\frac{1}{2}$ VS 820J
R9	Carbon film 3.3k	RD $\frac{1}{2}$ VS 332J
R10	Carbon film 18k	RD $\frac{1}{2}$ VS 183J
R11	Carbon film 100	RD $\frac{1}{2}$ PS 101J
R12	Carbon film 910	RD $\frac{1}{2}$ PM 911J
R13	Carbon film 1k	RD $\frac{1}{2}$ PS 102J
R14	Carbon film 11k	RD $\frac{1}{2}$ PS 113J
R15	Carbon film 120	RD $\frac{1}{2}$ PS 121J
R16	Carbon film 470	RD $\frac{1}{2}$ PS 471J
R17	Carbon film 470	RD $\frac{1}{2}$ PS 471J
R18	Carbon film 15k	RD $\frac{1}{2}$ PS 153J
R19	Carbon film 47k	RD $\frac{1}{2}$ PS 473J
R20	Carbon film 47k	RD $\frac{1}{2}$ PS 473J
R21	Carbon film 750	RD $\frac{1}{2}$ PS 751J
R22	Carbon film 2.2k	RD $\frac{1}{2}$ PS 222J
R23	Carbon film 5.6k	RD $\frac{1}{2}$ PS 562J
R24	Carbon film 560k	RD $\frac{1}{2}$ PS 564J
R25	Carbon film 12k	RD $\frac{1}{2}$ PS 123J

Symbol	Description	Part No.
R26	Carbon film 2.2k	RD%PS 222J
R27	Carbon film 10k	RD%PS 103J
R28	Carbon film 100k	RD%PS 104J
R29	Carbon film 10	RD%PS 100J
R30	Carbon film 30k	RD%PS 303J
R31	Carbon film 30k	RD%PS 303J
R32	Carbon film 6.8k	RD%PS 682J
R33	Carbon film 6.8k	RD%PS 682J
R34	Carbon film 47k	RD%PS 473J
R35	Carbon film 47k	RD%PS 473J
R36	Carbon film 3.3k	RD%PS 332J
R37	Carbon film 3.3k	RD%PS 332J
R38	Carbon film 2.2k	RD%PS 222J
R39	Carbon film 5.6k	RD%PS 562J
R40	Metal film 16k	RN%PT 1602F
R41	Carbon film 1k	RD%PS 102J
R42	Carbon film 100k	RD%PS 104J
R43	Carbon film 150	RD%PS 151J
R44	Carbon film 3.3k	RD%PS 332J
R45	Carbon film 3.3k	RD%PS 332J
R46	Carbon film 47k	RD%PS 473J
R47	Carbon film 47k	RD%PS 473J
R48	Carbon film 300k	RD%PS 304J
R49	Carbon film 300k	RD%PS 304J
R50	Carbon film 6.8k	RD%PS 682J
R51	Carbon film 6.8k	RD%PS 682J
R52	Carbon film 330k	RD%PS 334J
R53	Carbon film 330k	RD%PS 334J
R54	Carbon film 100k	RD%PS 104J
R55	Carbon film 100k	RD%PS 104J
R56	Carbon film 5.1k	RD%PS 512J
R57	Carbon film 39k	RD%PS 393J
R58	Carbon film 3.3k	RD%PS 332J
R59	Carbon film 680	RD%PS 681J
R60	Carbon film 1k	RD%PS 102J
R61	Carbon film 47	RD%PS 470J
R62	Carbon film 2.2k	RD%PS 222J
R63	Carbon film 2.2k	RD%PS 222J
R64	Carbon film 100k	RD%PS 104J
R65	Carbon film 100	RD%PS 101J
R66	Carbon film 100k	RD%PS 104J
R67	Carbon film 2.2k	RD%PS 222J
R68	Carbon film 100k	RD%PS 104J
R69	Carbon film 47k	RD%PS 473J
R70	Carbon film 1.5k	RD%PS 152J
R71	Carbon film 75k	RD%PS 753J
R72	Carbon film 910k	RD%PS 914J
R73	Carbon film 560	RD%PS 561J
R74	Carbon film 1.2k	RD%PS 122J
R75	Carbon film 100k	RD%PS 104J

Symbol	Description	Part No.
R76	Carbon film 100k	RD%PS 104J
R77	Carbon film 2.2k	RD%PS 222J
R78	Carbon film 100k	RD%PS 104J
R79	Carbon film 47k	RD%PS 473J
R80	Carbon film 1.5k	RD%PS 152J
R81	Carbon film 75k	RD%PS 753J
R82	Carbon film 910k	RD%PS 914J
R83	Carbon film 560	RD%PS 561J
R84	Carbon film 150	RD%PS 151J
R85	Carbon film 15k	RD%PS 153J
R86	Carbon film 15k	RD%PS 153J
R87	Carbon film 1k	RD%PS 102J
R88	Carbon film 1k	RD%PS 102J
R89	Carbon film 1.2k	RD%PS 122J
R90	Carbon film 100k	RD%PS 104J
R91	Carbon film 2.7k	RD%PS 272J
R92	Carbon film 2.2k	RD%PS 222J
R93	Carbon film 150k	RD%PS 154J
R94	Carbon film 270k	RD%PS 274J
R95	Carbon film 18k	RD%PS 183J
R96	Carbon film 91k	RD%PS 913J
R97	Carbon film 180	RD%PS 181J
R98	Carbon film 5.6k	RD%PS 562J
R99	Carbon film 560k	RD%PS 564J
R100	Carbon film 1k	RD%PS 102J
R101	Carbon film 2.2k	RD%PS 222J
R102	Carbon film 2.2k	RD%PS 222J
R103	Carbon film 2.2k	RD%PS 222J
R104	Carbon film 2.2k	RD%PS 222J
R105	Carbon film 2.2k	RD%PS 222J
R106	Carbon film 2.2k	RD%PS 222J
R107	Carbon film 390k	RD%PS 394J
R108	Carbon film 390k	RD%PS 394J
R109	Carbon film 100k	RD%PS 104J
R110	Carbon film 100k	RD%PS 104J
R111	Carbon film 68k	RD%PS 683J
R112	Carbon film 68k	RD%PS 683J

CAPACITORS

Symbol	Description	Part No.
	Variable capacitor	ACK-012
	Ceramic trimmer	ACM-006
C1	Ceramic 15p 50V	CCDTH 150K 50
C2	Ceramic 22p 50V	CCDSL 220K 50
C3	Ceramic 18p 50V	CCDTH 180K 50
C4	Ceramic 0.75p 500V	CGB R 75K 500
C5	Ceramic 0.01 50V	CKDYF 103Z 50

Symbol	Description			Part No.
C6	Ceramic	18p	50V	CCDSH 180K 50
C7	Ceramic	8p	50V	CCDCH 080F 50
C8	Ceramic	33p	50V	CCDCH 330K 50
C9	Ceramic	15p	50V	CCDCH 150K 50
C10	Ceramic	0.01	50V	CKDYB 103K 50
C11	Ceramic	0.47p	5000V	CGB R47K 500
C12	Ceramic	8p	50V	CCDSL 080F 50
C13	Ceramic	0.01	50V	CCDSL 103K 50
C14	Ceramic	100p	50V	CCDSL 101K 50
C15	Ceramic	0.04	50V	CKDYF 403Z 50
C16	Ceramic	0.01	50V	CKDYF 103Z 50
C17	Ceramic	0.04	50V	CKDYF 403Z 50
C18	Ceramic	0.04	50V	CKDYF 403Z 50
C19	Ceramic	0.047	50V	CKDBC 473Z 50
C20	Ceramic	0.047	50V	CKDBC 473Z 50
C21	Ceramic	0.047	50V	CKDBC 473Z 50
C22	Ceramic	330p	50V	CKDYB 331K 50
C23	Electrolytic	4.7	35V	CEA 4R7P 35
C24	Electrolytic	10	16V	CSZA 100M 16
C25	Ceramic	0.04	50V	CKDYF 403Z 50
C26	Ceramic	0.04	50V	CKDYF 403Z 50
C27	Ceramic	0.04	50V	CKDYF 403Z 50
C28	Ceramic	0.04	50V	CKDYF 403Z 50
C29	Electrolytic	4.7	35V	CEA 4R7P 35
C30	Electrolytic	0.47	50V	CEA R47P 50
C31	Electrolytic	10	16V	CSZA 100M 16
C32	Ceramic	0.047	50V	CKDBC 473Z 50
C33	Electrolytic	470	16V	CEA 471P 16
C34	Electrolytic	1	25V	CSZA 010M 25
C35	Electrolytic	3.3	10V	CSZA 3R3M 10
C36	Polystyrene film	510p	50V	CQSH 511J 50
C37	Electrolytic	0.22	25V	CSZA R22M 25
C38	Ceramic	82p	50V	CCDSL 820K 50
C39	Electrolytic	10	16V	CEA 100P 16
C40	Electrolytic	10	16V	CEA 100P 16
C41	Polystyrene film	510p	50V	CQSA 511J 50
C42	Polystyrene film	510p	50V	CQSA 511J 50
C43	Electrolytic	2.2	25V	CSZA 2R2M 25
C44	Electrolytic	2.2	25V	CSZA 2R2M 25
C45	Electrolytic	0.1	25V	CSZA 0R1M 25
C46	Electrolytic	0.1	25V	CSZA 0R1M 25
C47	Electrolytic	0.1	25V	CSZA 0R1M 25
C48	Electrolytic	0.1	25V	CSZA 0R1M 25
C49	Electrolytic	0.47	25V	CSZA R47M 25
C50	Electrolytic	0.47	25V	CSZA R47M 25
C51	Ceramic	0.04	50V	CKDYF 403Z 50
C52	Ceramic	12p	50V	CCDXL 120K 50
C53	Polystyrene film	330p	50V	CQSA 331J 50
C54	Ceramic	0.01	50V	CKDYF 103Z 50
C55	Ceramic	0.04	50V	CKDYF 403Z 50

Symbol	Description			Part No.
C56	Ceramic	0.01	50V	CKDYF 103Z 50
C57	Ceramic	0.01	50V	CKDYF 103Z 50
C58	Electrolytic	10	16V	CEA 100P 16
C59	Ceramic	0.04	50V	CKDYF 403Z 50
C60	Ceramic	0.04	50V	CKDYF 403Z 50
C61	Electrolytic	47	6V	CEA 470P 6
C62	Electrolytic	4.7	35V	CEA 4R7P 35
C63	Ceramic	220p	50V	CCDSL 221K 50
C64	Electrolytic	220	16V	CEA 221P 16
C65	Ceramic	0.01	50V	CKDYF 103Z 50
C66	Ceramic	0.022	50V	CKDYF 223Z 50
C67	Mylar	0.056	50V	CQMA 563K 50
C68	Ceramic	0.04	50V	CKDYF 403Z 50
C69	Ceramic	0.04	50V	CKDYF 403Z 50
C70	Electrolytic	220	6V	CEA 221P 6
C71	Ceramic	0.04	50V	CKDYF 403Z 50
C72	Ceramic	0.04	50V	CKDYF 403Z 50
C73	Ceramic	0.04	50V	CKDYF 403Z 50
C74	Ceramic	68p	50V	CCDSL 680K 50
C75	Ceramic	68p	50V	CCDSL 680K 50
C76	Electrolytic	2.2	25V	CSZA 2R2M 25
C77	Electrolytic	2.2	25V	CSZA 2R2M 25
C78	Ceramic	47p	50V	CCDSL 470K 50
C79	Ceramic	0.04	50V	CCDSL 403K 50
C80	Ceramic	15p	50V	CCDSL 150K 50
C81	Ceramic	15p	50V	CCDSL 150K 50
C82	Ceramic	15p	50V	CCDSL 150K 50
C83	Ceramic	15p	50V	CCDSL 150K 50
C84	Electrolytic	100	6V	CEA 101P 6
C85	Electrolytic	100	6V	CEA 101P 6
C86	Polystyrene film	1000p	50V	COSA 102G 50
C87	Polystyrene film	1000p	50V	CQSA 102G 50
C88	Polystyrene film	3500p	50V	CQSA 352G 50
C89	Polystyrene film	3500p	50V	CQSA 352G 50
C90	Electrolytic	2.2	25V	CSZA 2R2M 25
C91	Electrolytic	2.2	25V	CSZA 2R2M 25
C92	Ceramic	220p	50V	CCDSL 221K 50
C93	Ceramic	220p	50V	CCDSL 221K 50
C94	Electrolytic	220	25V	CEA 221P 25
C95	Electrolytic	220	25V	CEA 221P 25
C96	Ceramic	330p	50V	CKDYB 331K 50
C97	Ceramic	330p	50V	CKDYB 331K 50
C98	Mylar	0.022	50V	CQMA 223K 50
C99	Mylar	0.022	50V	CQMA 223K 50
C100	Electrolytic	1	25V	CSZA 010M 25
C101	Electrolytic	47	10V	CEA 470P 10
C102	Ceramic	100p	50V	CCDSL 101K 50
C103	Ceramic	1800p	50V	CKDYB 182K 50
C104	Electrolytic	0.1	35V	CSZA 0R1M 35
C105	Electrolytic	100	35V	CEA 101P 35
C106	Ceramic	0.04	50V	CKDYF 403Z 50
C107	Ceramic	0.04	50V	CKDYF 403Z 50
C108	Mylar	0.047	50V	CQMA 473K 50
C109	Ceramic	47p	50V	CCDSL 470K 50

13. PACKING

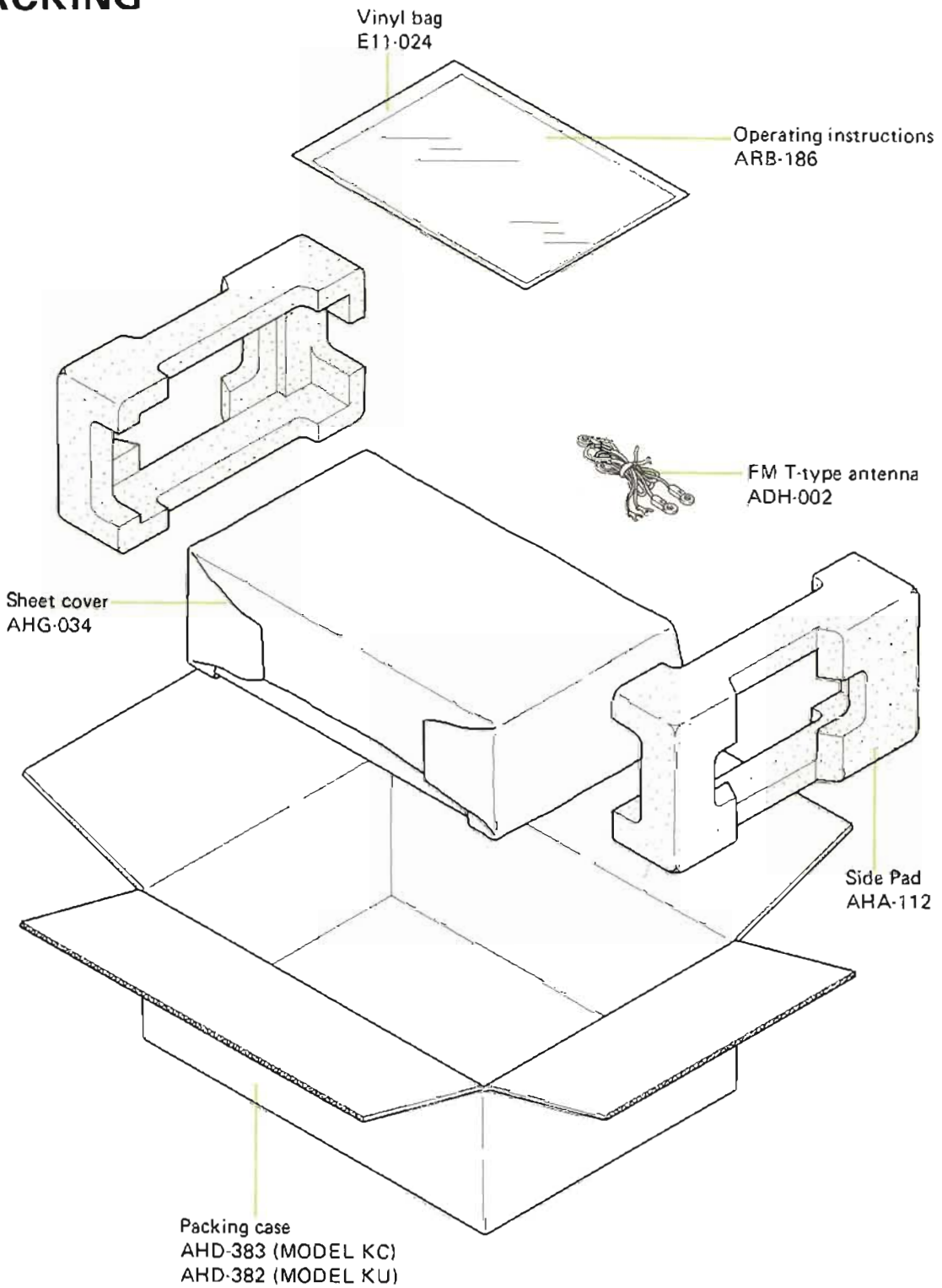

OTHERS

Symbol	Description	Part No.
	Vinyl bag (power cord cover)	AHG-023
	Vinyl cover (ferrite bar-antenna cover)	AHG-040

AM/FM STEREO RECEIVER
SX-650
HG, S

Additional

Service Manual

NOTE:

This leaflet provides the description of the parts applies only to the HG, S models.
For detailed please refer to the Service Manual of SX-650/KCU.

 **PIONEER®**

1. SPECIFICATIONS

Power Requirements 120V 60Hz MODEL KC, KU
 220V and 240V (Switchable) MODEL HG
 110V, 120V, 220V and 240V (Switchable) MODEL S
 Power Consumption . . . UL, 80W, 185W (max.) MODEL KC, KU
 185W MODEL HG
 185W MODEL S

2. CONTRAST OF MISCELLANEOUS PARTS

FUSES

Symbol	Amp	Part No.			Remarks
		KCU type	HG type	S type	
FU1	1.5A	AEK-104	AEK-104	
	1.6A	AEK-405	
FU2	0.8A	AEK-111	AEK-031	AEK-111	
FU3	0.8A	AEK-111	AEK-031	AEK-111	
FU4	3A	AEK-101	AEK-101	Primary voltage: 220V, 240V
	1.6A	AEK-405	Primary voltage: 110V, 120V
	1.5A	AEK-104	

SWITCHES

Symbol	Part Name	Part No.			Remarks
		KCU type	HG type	S type	
S1	Selector	ASA-039	ASA-040	ASA-038	POWER
S2	Plug in selector (Line voltage selector)	AKX-037	2-positions
		AKR-033	4-positions with fuse holder

TRANSFORMER

Symbol	Part Name	Part No.			Remarks
		KCU type	HG type	S type	
T1	Power transformer	ATT-315 (KC) ATT-303 (KU)	ATT-340	ATT-339	

RESISTOR

Symbol	Part Name	Part No.			Remarks
		KCU type	HG type	S type	
R1	Carbon film 2.2M $\frac{1}{4}$ W	RD $\frac{1}{2}$ PS 225J	

CAPACITORS

Symbol	Part Name			Part No.			Remarks
				KCU type	HG type	S type	
C3	Ceramic	0.01	150V	ACG-003	
	Ceramic	0.01	250V	ACG-001	ACG-001	
C4	Ceramic	0.01	150V	ACG-003 (KC)	
	Ceramic	0.01	250V	ACG-001 (KU)	ACG-001	
	Polystyrene	560P	50V	CQSA 561J 50	
C5	Polystyrene	560P	50V	CQSA 561J 50	

P.C. BOARD ASSEMBLIES

Part Name	Part No.			Remarks
	KCU type	HG type	S type	
De-emphasis switch assembly	AWX-095	2-positions (25 μ s/75 μ s)
	AWX-100	3-positions (25 μ s/50 μ s/75 μ s)
Power supply assembly	AWR-117	AWR-118	AWR-117	

OTHERS

Part Name	Part No.			Remarks
	KCU type	HG type	S type	
AC power cord	ADG-005	ADG-002	
AC socket (OUTLET)	AKP-004	AKP-004	
AC socket (INLET)	AKP-008	
Woodencabinet	AAM-054	AAM-053	AAM-054	
Rubber mat	AEB-075	AEB-077	AEB-077	
Capacitor cover	AEC-279	AEC-099	AEC-099	
	AEC-294 (KU)	
Terminal board (2P)	AKC-038	AKC-030	
Operating instructions	ARB-186	ARB-187	ARB-195	English
	ARD-095	German/French
Packing case	AHD-383 (KC)	AHD-384	AHD-382	
	AHD-382 (KU)	

3. MODEL SX-650/HG

NOTE:
Parts indicated in green type cannot be supplied.

3.1 REAR PANEL

A

A

B

B

C

C

D

D

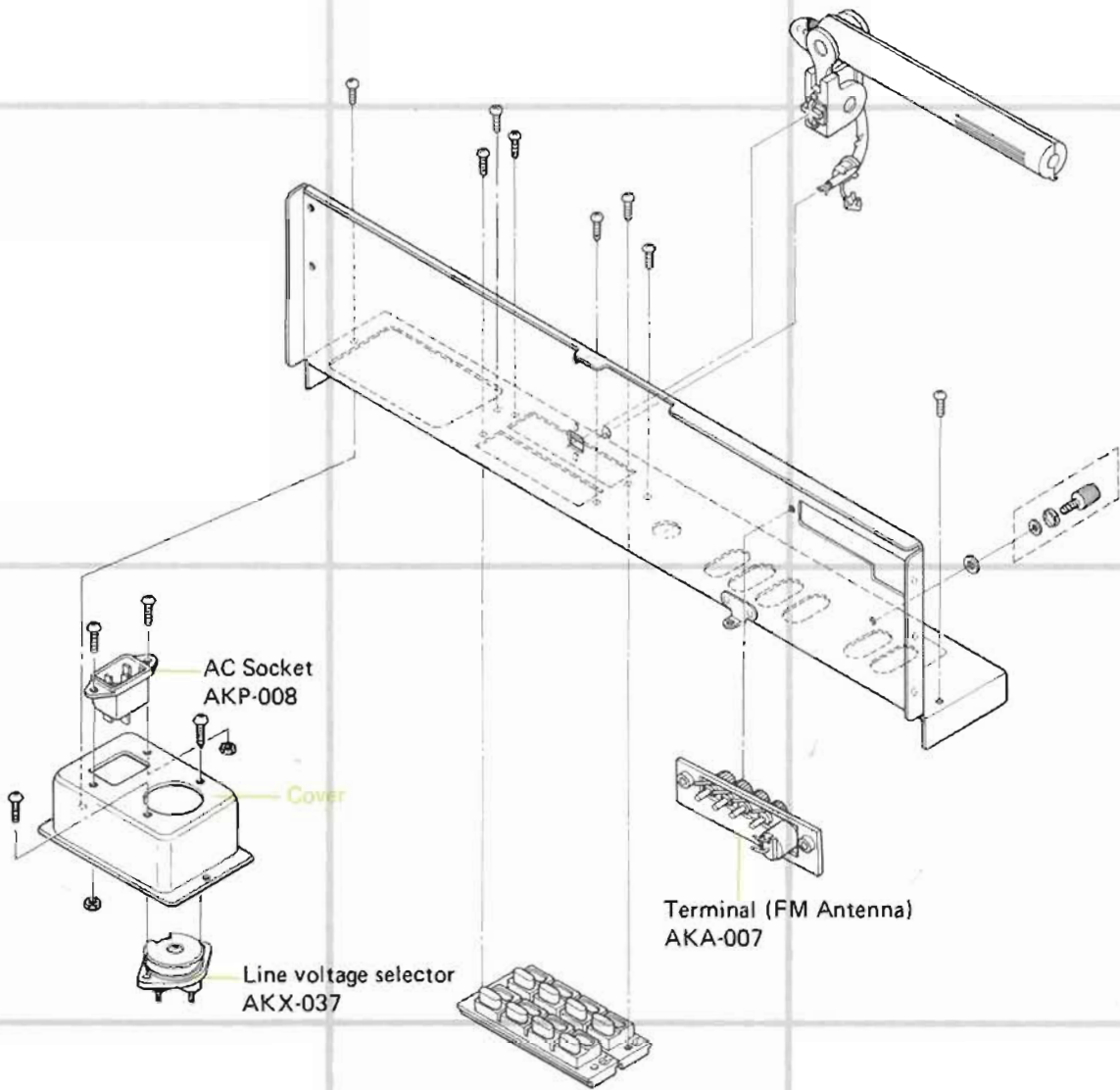

1

2

3

3.2 SCHEMATIC DIAGRAM

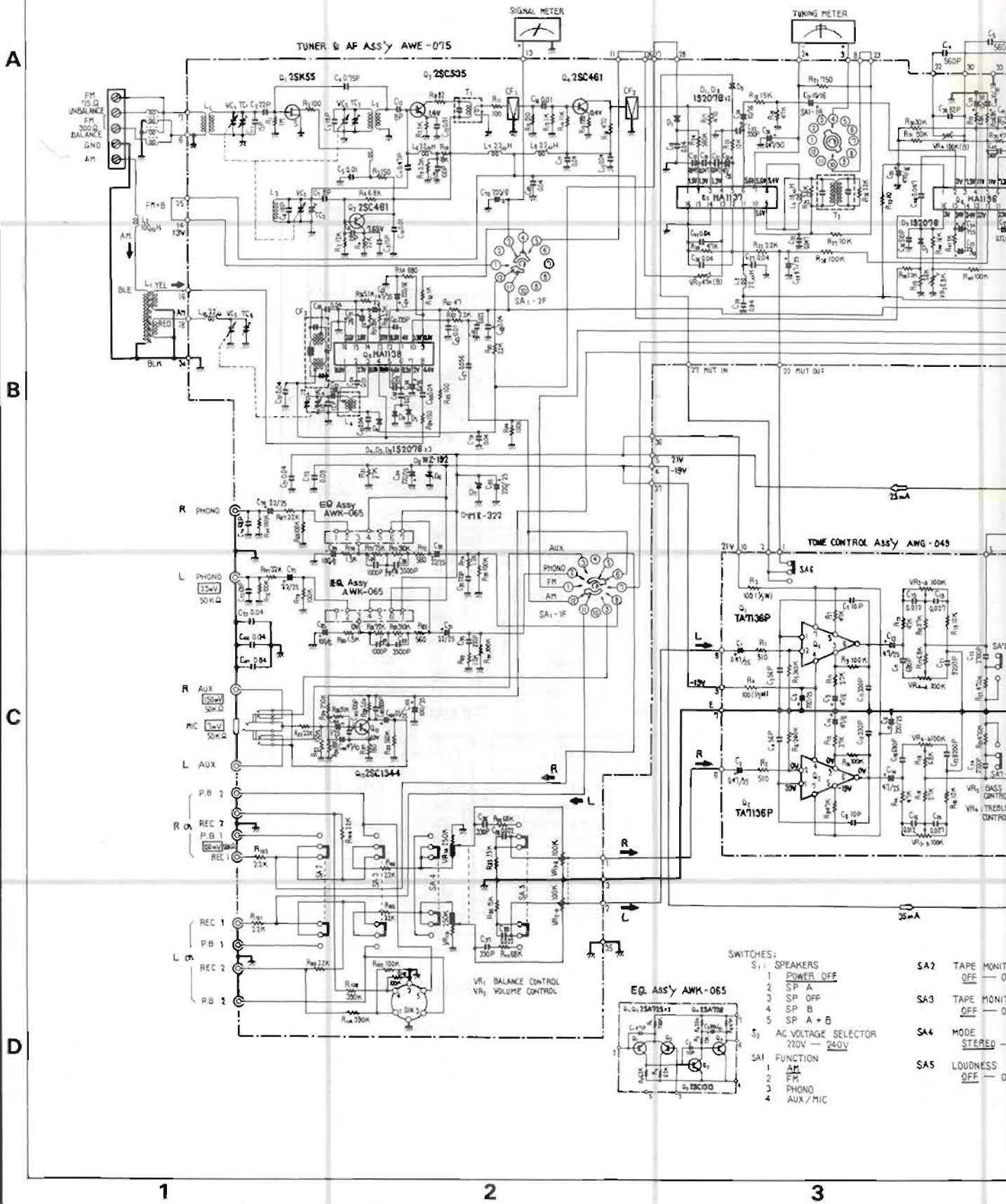

- SWITCHES:
- S1: SPEAKERS
 - S2: AC VOLTAGE SELECTOR 220V 240V
 - SA1: FUNCTION
 - 1 AM
 - 2 FM
 - 3 PHONO
 - 4 AUX/MIC
 - SA2: TAPE MONIT OFF - O
 - SA3: TAPE MONIT OFF - O
 - SA4: MODE STEREO
 - SA5: LOUDNESS OFF - O

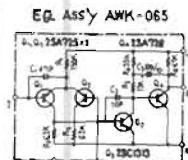

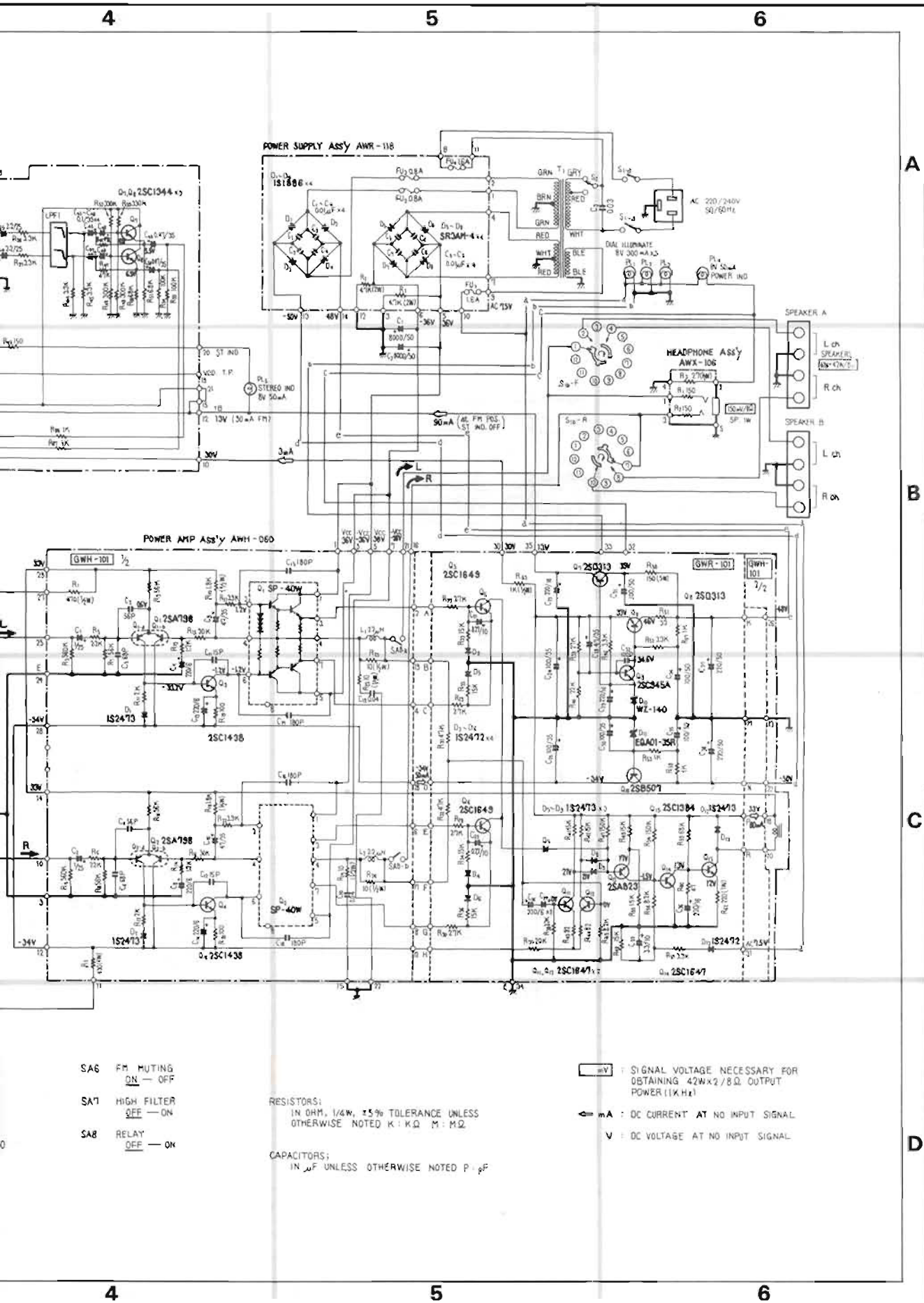

A

B

C

D

4

5

6

4

5

6

3.3 POWER SUPPLY ASSEMBLY (AWR-118)

A
B
C
D

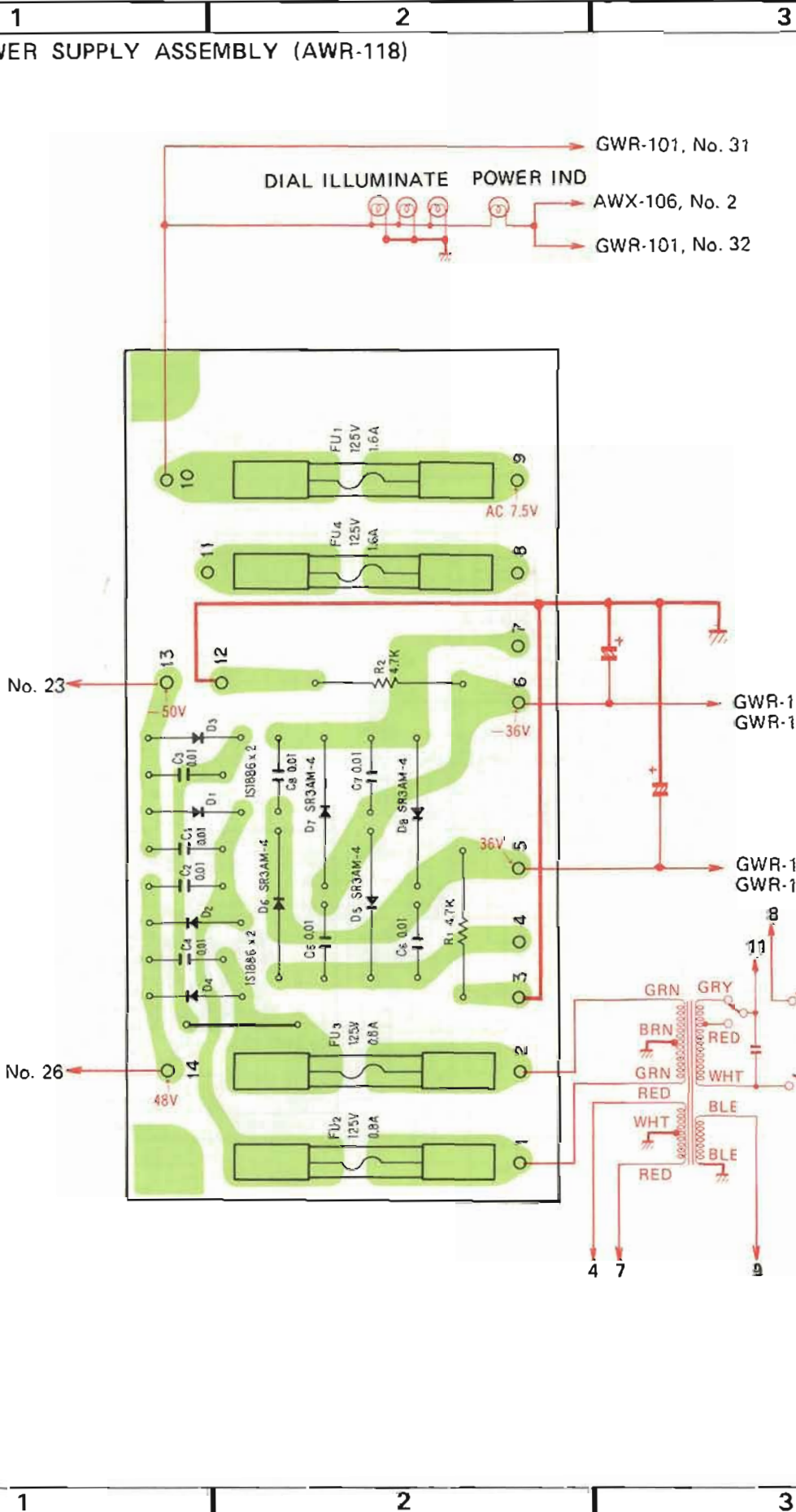

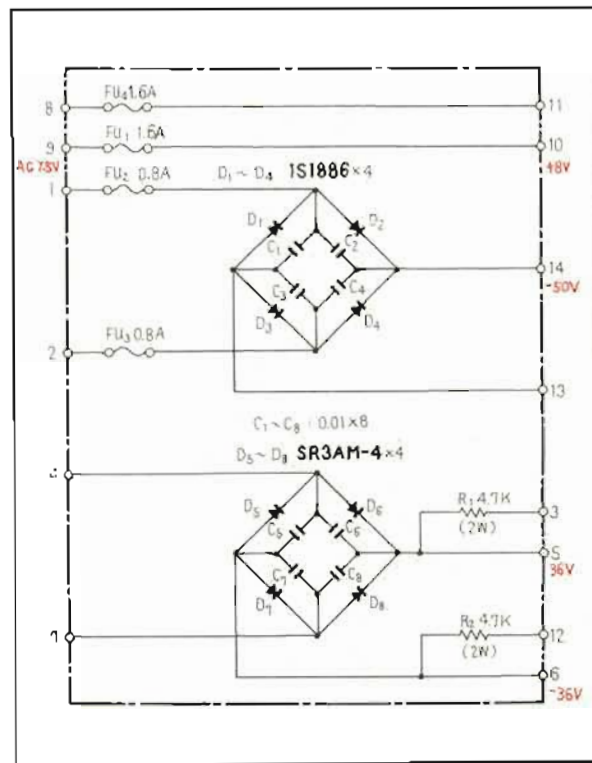

Parts List

SEMICONDUCTORS

Symbol	Description	Part No.
D1	Diode	1S1886 (S1B01-02)
D2	Diode	1S1886 (S1B01-02)
D3	Diode	1S1886 (S1B01-02)
D4	Diode	1S1886 (S1B01-02)
D5	Diode	SR3AM-4
D6	Diode	SR3AM-4
D7	Diode	SR3AM-4
D8	Diode	SR3AM-4

CAPACITORS

Symbol	Description	Part No.
C1	Ceramic 0.01 150V	ACG-004-0
C2	Ceramic 0.01 150V	ACG-004-0
C3	Ceramic 0.01 150V	ACG-004-0
C4	Ceramic 0.01 150V	ACG-004-0
C5	Ceramic 0.01 150V	ACG-004-0
C6	Ceramic 0.01 150V	ACG-004-0
C7	Ceramic 0.01 150V	ACG-004-0
C8	Ceramic 0.01 150V	ACG-004-0

RESISTORS

Symbol	Description	Part No.
R1	Metal oxide 4.7k 2W	RS2P 472K
R2	Metal oxide 4.7k 2W	RS2P 472K

OTHERS

Symbol	Description	Part No.
	Fuse clip	AKR-013

4. MODEL SX-650/S

4.1 SCHEMATIC DIAGRAM

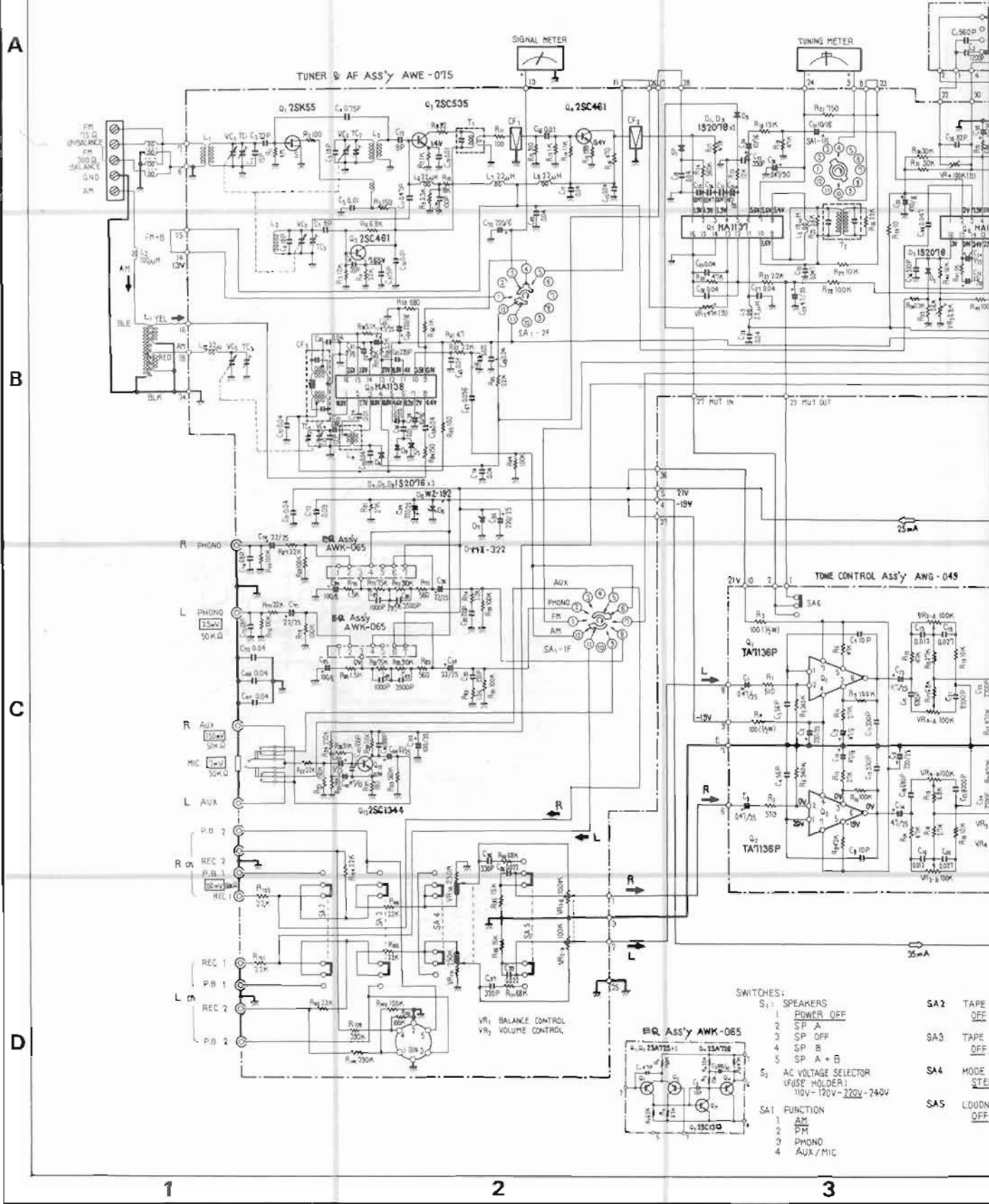

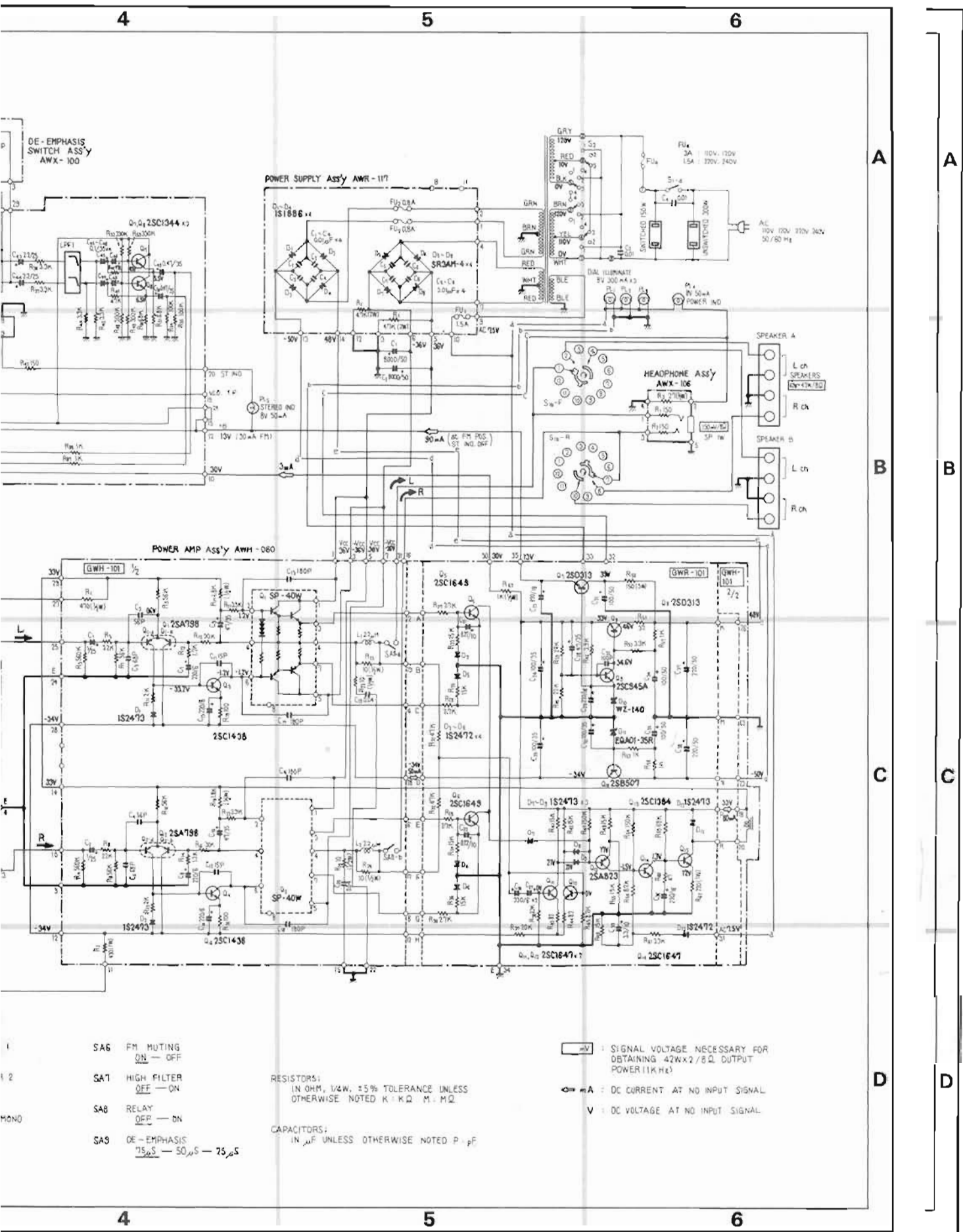

- SA6 FM MUTING
ON — OFF
- SA1 HIGH FILTER
OFF — ON
- SA8 RELAY
OFF — ON
- SA3 DE-EMPHASIS
75 μ S — 30 μ S — 75 μ S

RESISTORS:
IN OHM, 1/4W, \pm 5% TOLERANCE UNLESS
OTHERWISE NOTED K = K Ω M = M Ω

CAPACITORS:
IN μ F UNLESS OTHERWISE NOTED P = pF

\square -V : SIGNAL VOLTAGE NECESSARY FOR
OBTAINING 42W \times 2 / 8 Ω OUTPUT
POWER (1KHz)

\square -A : DC CURRENT AT NO INPUT SIGNAL

V : DC VOLTAGE AT NO INPUT SIGNAL

A A

B B

C C

D D

4.2 DE-EMPHASIS SWITCH ASSEMBLY (AWX-100)

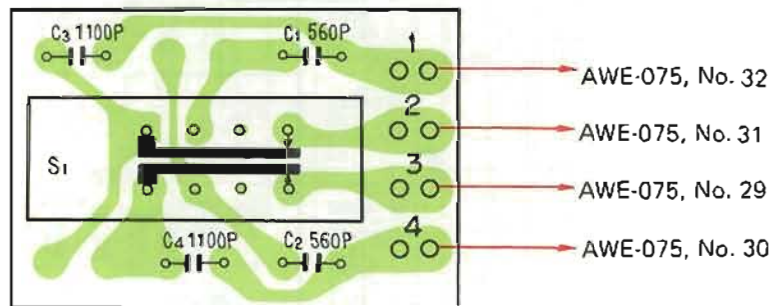
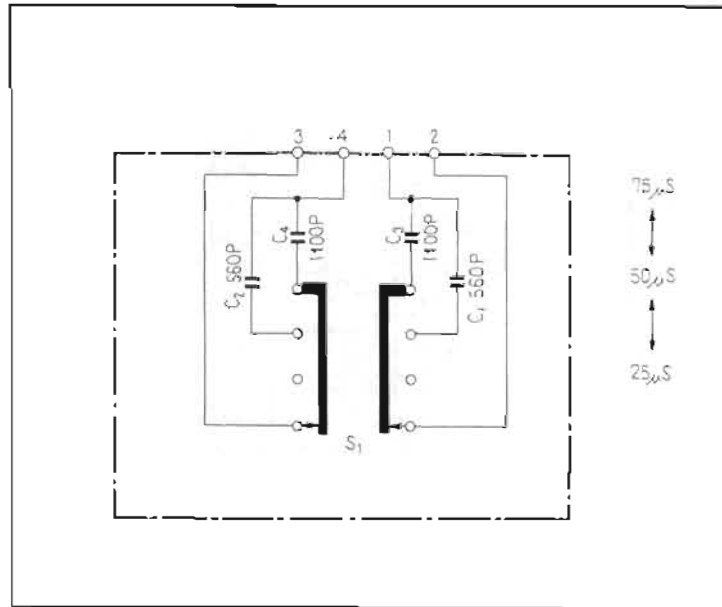

Parts List

Symbol	Description	Part No.
S1	Slide switch (DE-EMPHASIS)	ASH-017
C1	Polystyrene capacitor 560p 50V	CQSA 561J 50
C2	Polystyrene capacitor 560p 50V	CQSA 561J 50
C3	Mylar capacitor 0.0011 50V	CQMA 112J 50
C4	Mylar capacitor 0.0011 50V	CQMA 112J 50

4.3 REAR PANEL

NOTE:
Parts indicated in green type cannot be supplied.

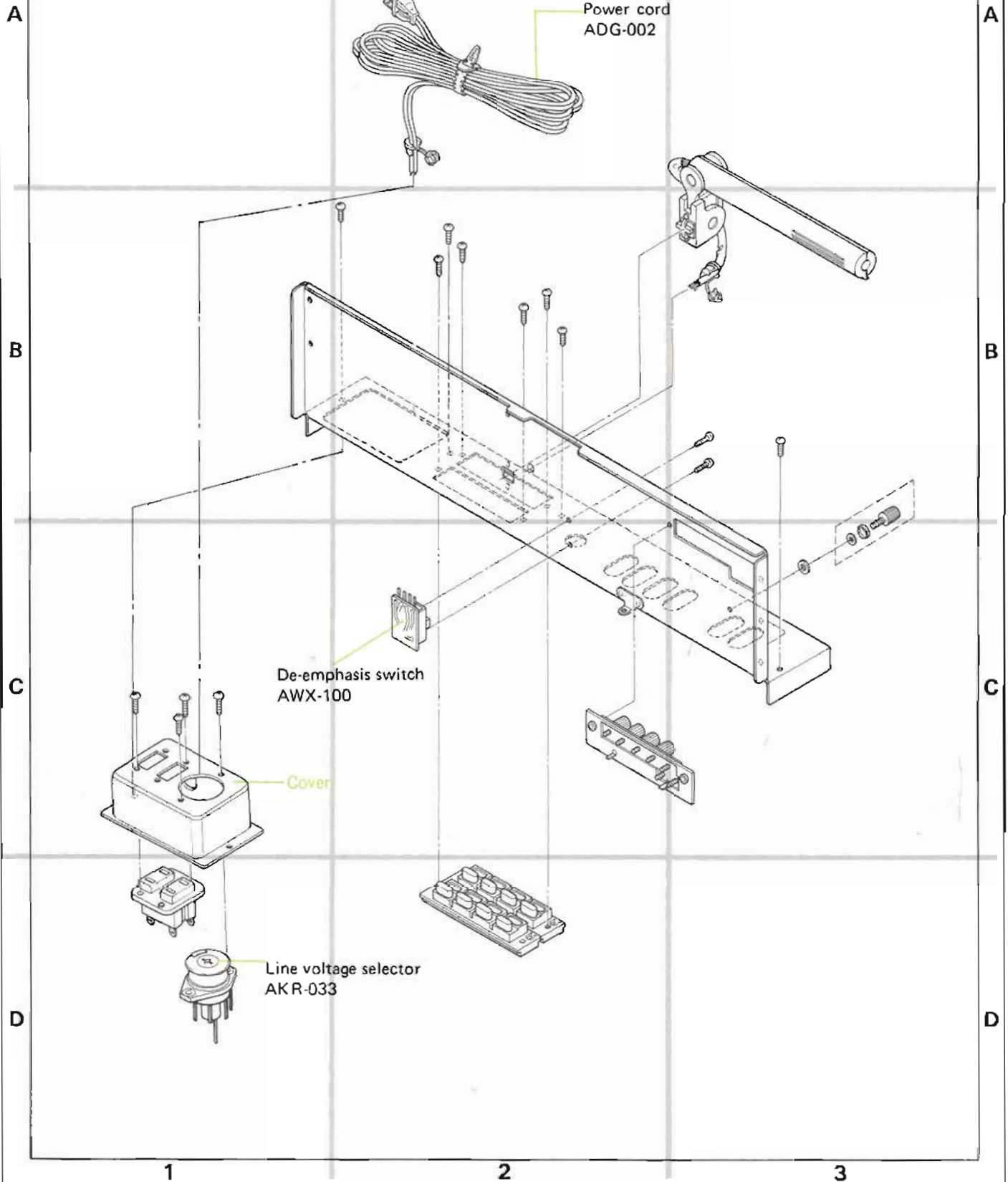

PIONEER ELECTRONIC CORPORATION

4-1, Meguro 1-Chome, Meguro-ku, Tokyo 153, Japan

U.S. PIONEER ELECTRONICS CORPORATION

75 Oxford Drive, Moonachie, New Jersey 07074, U.S.A.

PIONEER ELECTRONIC (EUROPE) N.V.

Luiithagen-Haven9, 2030 Antwerp, Belgium

PIONEER ELECTRONICS AUSTRALIA PTY. LTD.

178-184 Boundary Road, Braeside, Victoria 3195, Australia

AM/FM STEREO RECEIVER

SX-650

KU
KC

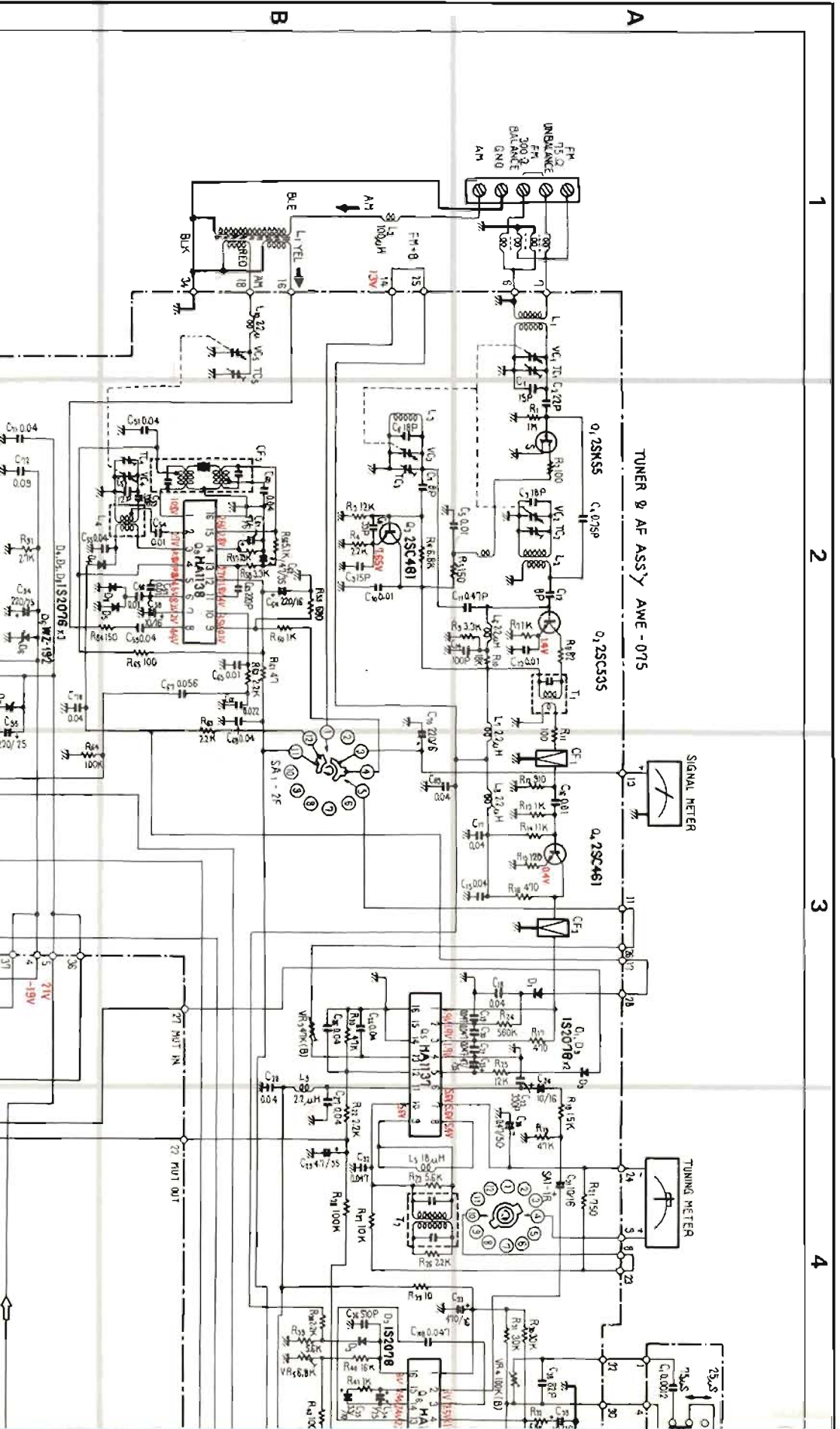

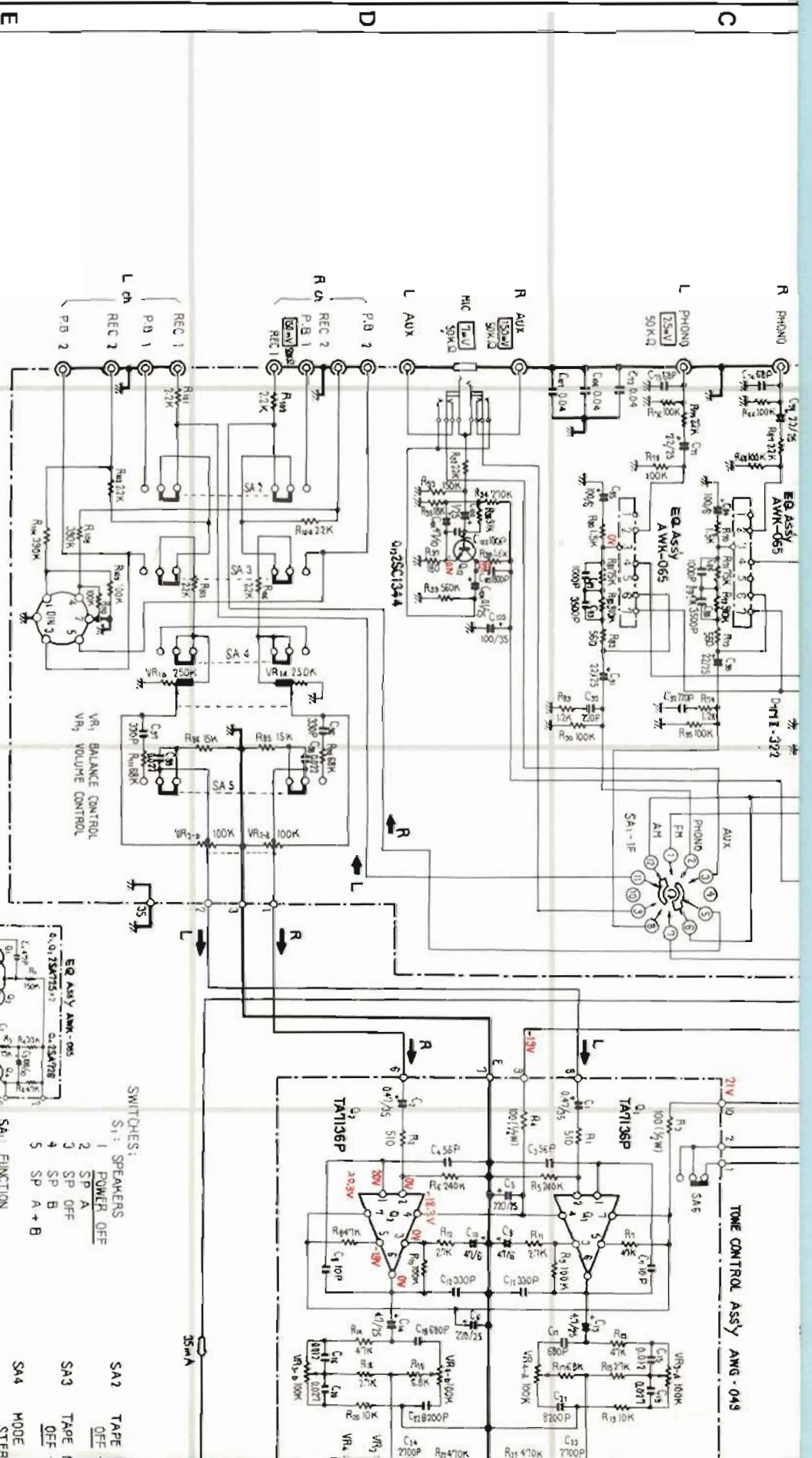

1 2 3 4

E

D

C

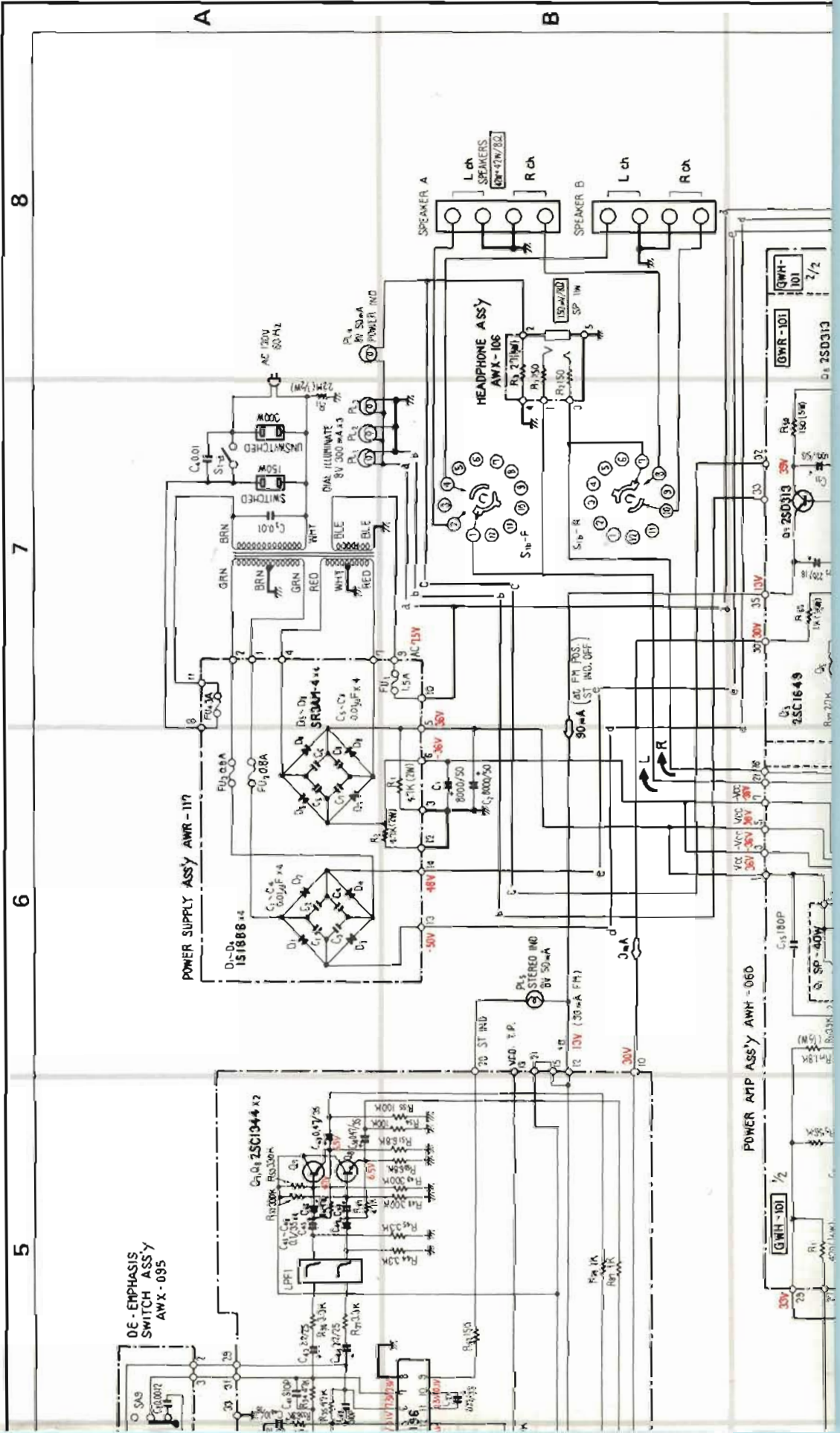

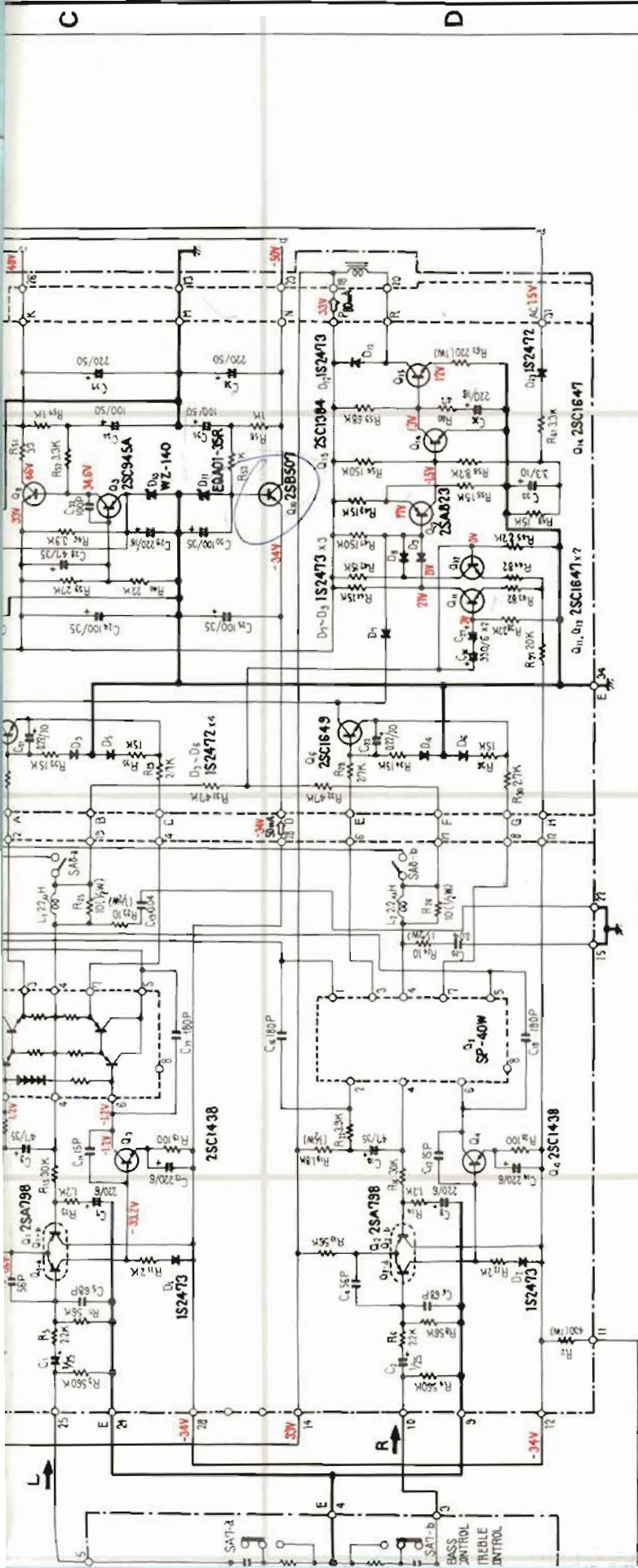

□ mV : SIGNAL VOLTAGE NECESSARY FOR OBTAINING 42Wx2 / 8 Ω OUTPUT POWER (1K Hz)
 ◀ mA : DC CURRENT AT NO INPUT SIGNAL
 V : DC VOLTAGE AT NO INPUT SIGNAL

RESISTORS:
 IN OHM, 1/4W, ±5% TOLERANCE UNLESS OTHERWISE NOTED K: K Ω M: M Ω
 CAPACITORS:
 IN μF UNLESS OTHERWISE NOTED P: pF

- MONITOR 1 — ON
- MONITOR 2 — ON
- EO — MONO
- SS — ON
- SA6 FM MUTING ON — OFF
- SA7 HIGH FILTER OFF — ON
- SA8 RELAY OFF — ON
- SA9 DE-EMPHASIS 75μS — 25μS

AM/FM STEREO RECEIVER

SX-6550 HG

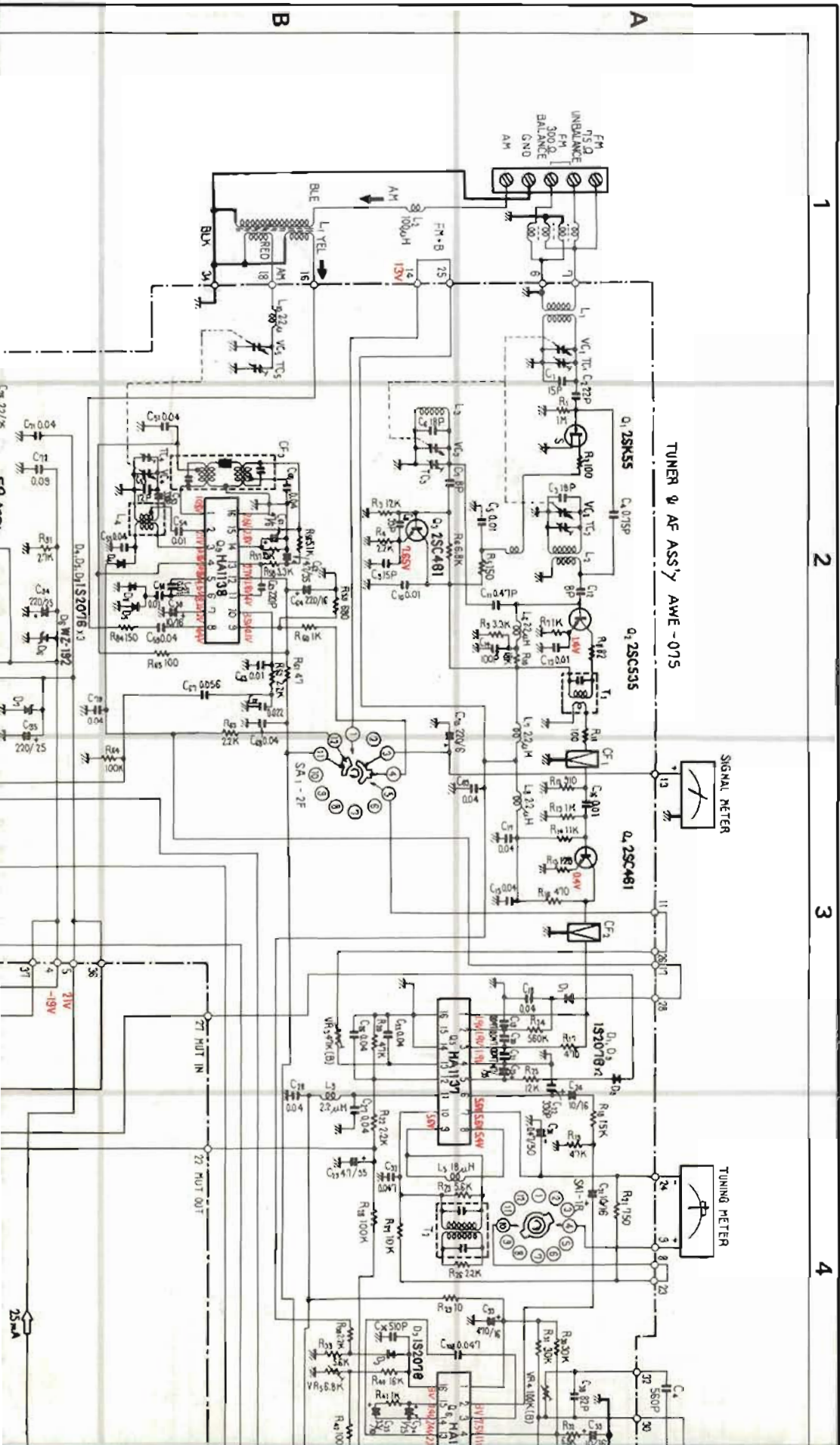

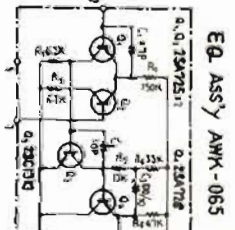
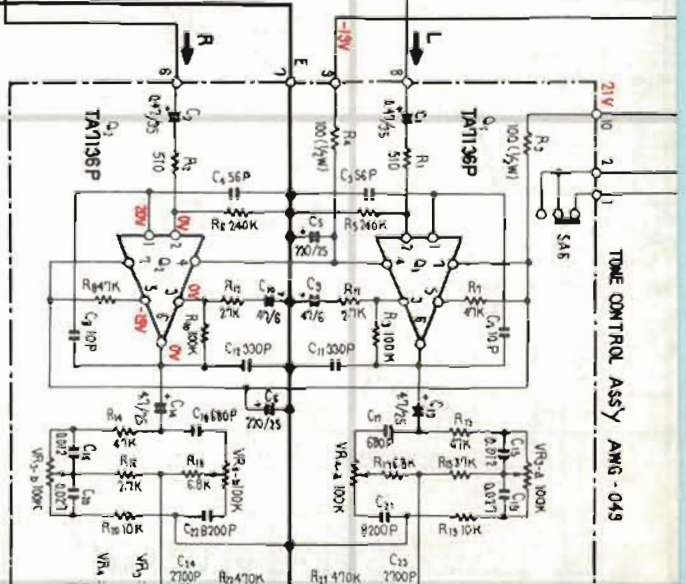
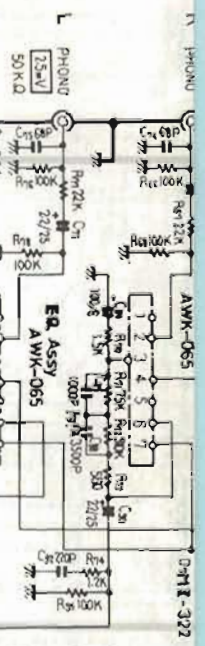
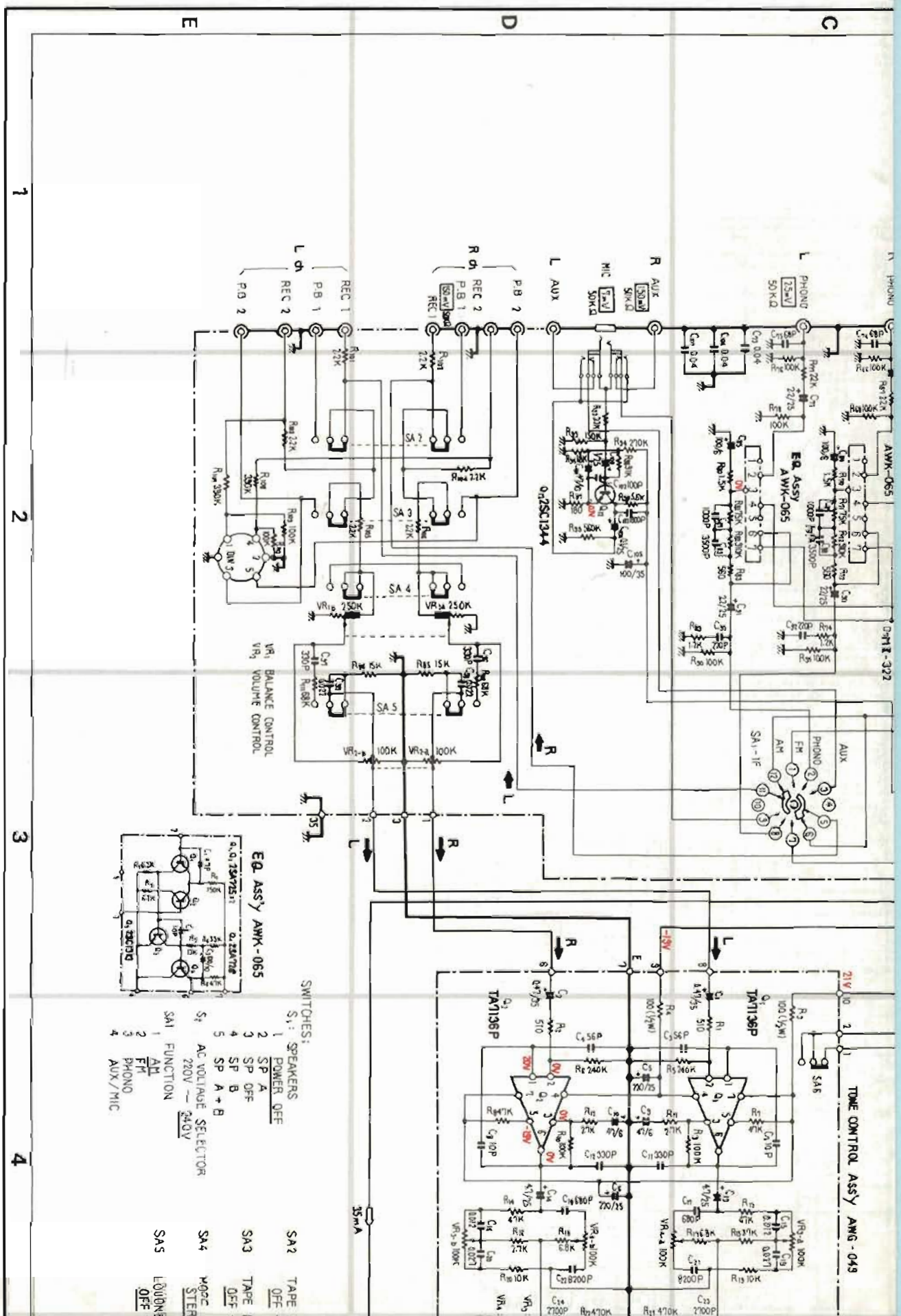

- SWITCHES:
- S1: SPEAKERS
 - S2: TAPES
 - S3: TAPE
 - S4: MODE
 - S5: FOLDONE
- FUNCTIONS:
- 1 SP A
 - 2 SP OFF
 - 3 SP B
 - 4 SP A + B
 - 5 AC VOLTAGE SELECTOR
 - 6 220V
 - 7 240V
 - 8 ALL
 - 9 PHONO
 - 10 AUX/MIC
 - 11 OFF
 - 12 TAPE
 - 13 OFF
 - 14 MODE
 - 15 STER
 - 16 FOLDONE
 - 17 OFF

1 2 3 4

E D C

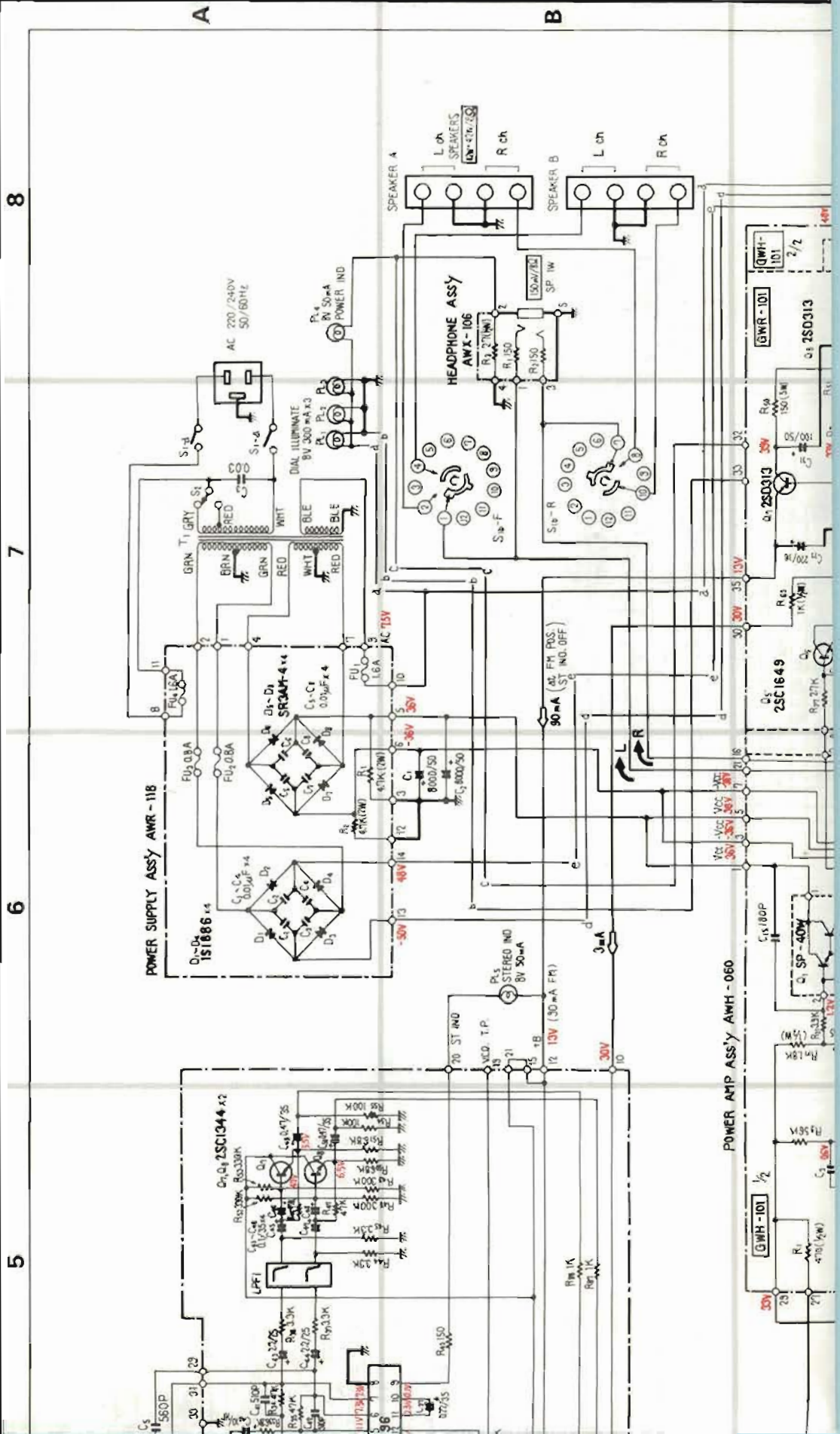

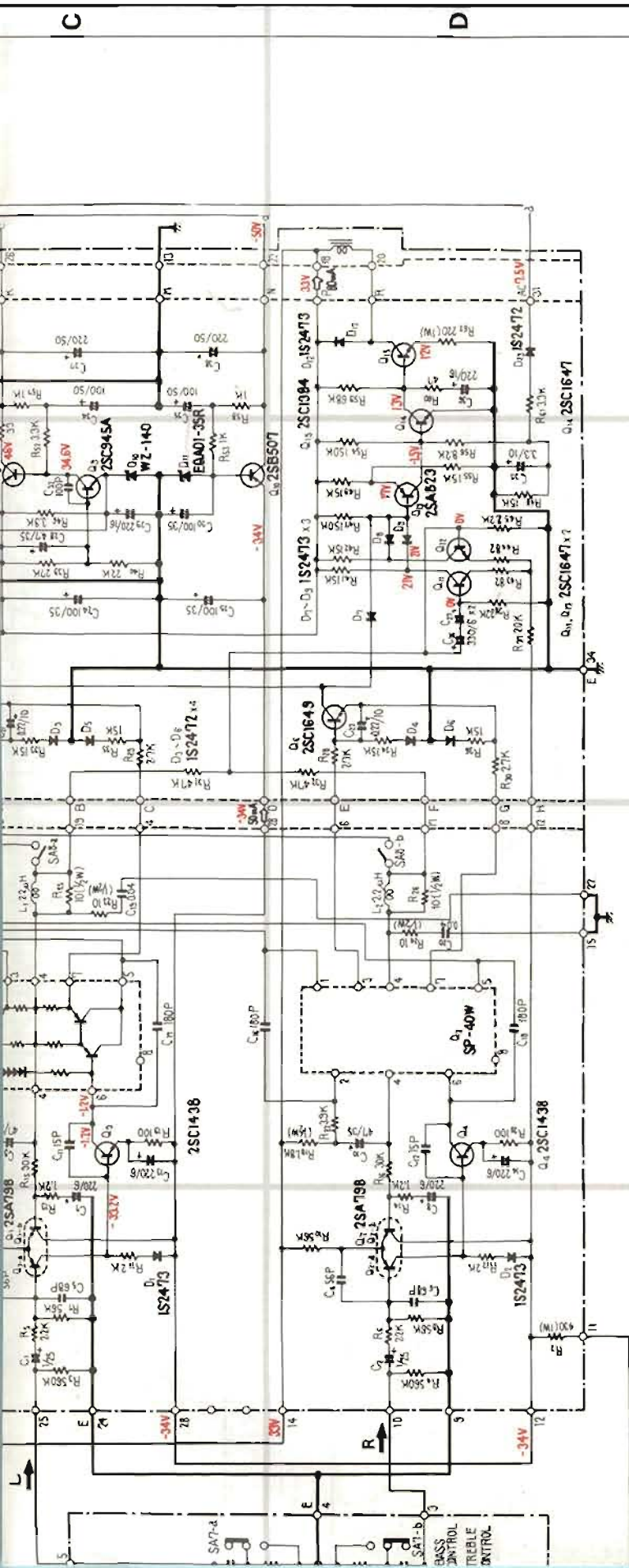

mV : SIGNAL VOLTAGE NECESSARY FOR
 OBTAINING 42W x 2 / 8Ω OUTPUT
 POWER (1KHz)

↔ mA : DC CURRENT AT NO INPUT SIGNAL
 V : DC VOLTAGE AT NO INPUT SIGNAL

RESISTORS:
 IN ΩM, 1/4W, ±5% TOLERANCE UNLESS
 OTHERWISE NOTED K: K.Ω M: M.Ω.

CAPACITORS:
 IN μF UNLESS OTHERWISE NOTED P: pF

- MONITOR 1 — ON
- MONITOR 2 — ON
- ED — MONO
- SS — ON
- SAB FM MUTING ON — OFF
- SAT HIGH FILTER OFF — ON
- SAB RELAY OFF — ON

5

6

7

8